

Size/Weight	16"H x 7.75"W x 19"D (407mm x 197mm x 483mm); 44.0 lbs. (20 kg)
Noise Level	(5 drives typical) LwAu = 5.6 Bels idling, LwAu = 6.0 Bels operating
Power	Low voltage (115 power supply setting) 90V-137 VAC 6.3 Amps 0.76 KVA 378 Watts High voltage (230 power supply setting) 180V-265 VAC 4.0 Amps 0.96 KVA 480 Watts
FCC class	A
CISPR	A
Japan VCCI	1
Operating Environment	Temperature = 16 to 32 degrees C (60.8 to 89.6 degrees F) Relative Humidity = 20 to 80 percent Wet Bulb = 23.0 degrees C (73.4 degrees F maximum) Voltage = 115/230 V

Hardware Layout Overview and Description

Control Panel

Power Switch Pushbutton switch used to set the power on or off.

Light-Emitting Diode (LED) When lit, indicates that the power switch is set to on and that the unit is receiving power.

Media Bays

Two media bays support CDROM, tape, and disk drive devices.

Hot-Swap Bays

Five hot-swap bays support 1.1 gigabyte (GB), 2.2GB, and 4.5GB single-ended SCSI-2 disk drives mounted on easily removable carriers.

Hot-Swap Carriers

Power Switch Each carrier contains a pushbutton power switch that allows power to be removed from/returned to each disk drive.

Green Light Each carrier contains a green light that indicates that power is applied to the disk drive. The normal state of this light should be ON. The green light will flash if the power switch on the carrier is pushed OFF or if the cooling fan is malfunctioning.

Yellow Light Each carrier contains a yellow light that indicates that the disk is spinning. The system software controls spin-up of the individual drives. The normal condition of the yellow light is ON when the 7131 is connected to the system and the disk drive is available.

Latch The latch locks the disk drive into the hot-swap bay to maintain connection with the bus. The carrier is locked into the bus when the latch is in the HORIZONTAL position. The carrier is unlocked when the latch is pointing down.

Voltage Selection Switch

The Voltage Selection Switch is a two-position switch on the power supply. The switch can be set to 115 volts AC or 230 volts AC. The switch must be set to match the input voltage at the wall outlet before connecting the linecord. The 7131 will not operate if the voltage selection does not match the wall outlet voltage. Refer to the information at the top of page 1 for supported voltage ranges for each switch setting.

WARNING: IF THE 7131 IS CONNECTED TO A HIGH VOLTAGE WALL OUTLET AND THE VOLTAGE SELECTION SWITCH IS SET TO 115, THE POWER SUPPLY WILL BE DAMAGED WHEN THE 7131 POWER SWITCH IS SET TO ON.

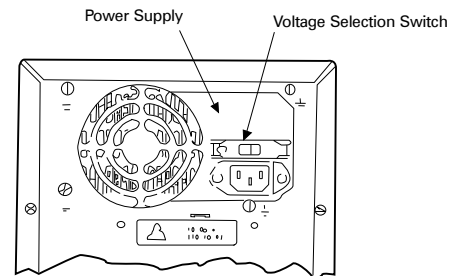
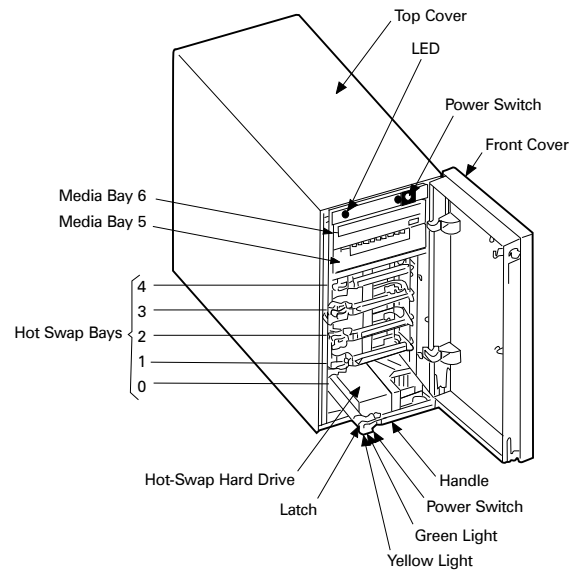

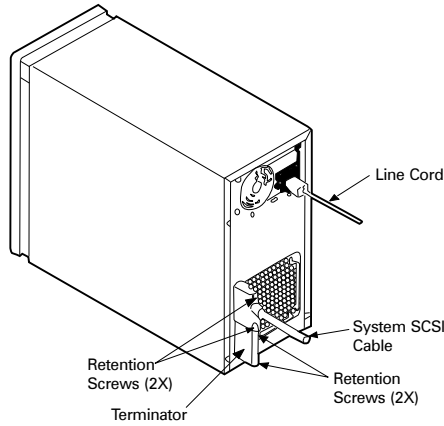

Power Supply

The power supply is mounted at the top rear of the 7131. The power supply is not auto-ranging.

Line Cord

The line cord connects directly to the power supply.

Cooling Fan

Cooling is provided by a fan mounted at the lower rear of the 7131 (behind the grill shown in the figure above).

System SCSI Cable

The 7131 supports attachment via SCSI-2 single-ended or differential-ended cabling. A SCSI bus terminator is NOT required on the 7131 when connecting via single-ended cabling. An optional Single-Ended to Differential (SE/DIFF) converter card must be installed in the 7131 to support attachment via differential cabling.

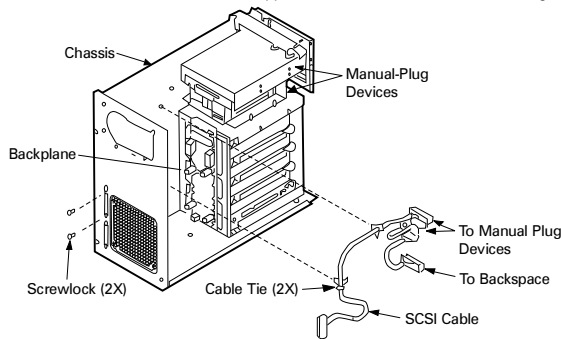

Cover Removal

Front Cover Removal

1. Open the front cover beyond a 90-degree angle.
2. Holding the top and bottom of the cover, lift it straight up to remove.

Top Cover Removal

1. Open the front cover.
2. Remove the four screws that fasten the top cover to the rear frame.
3. Lift and remove the top cover from the 7131.

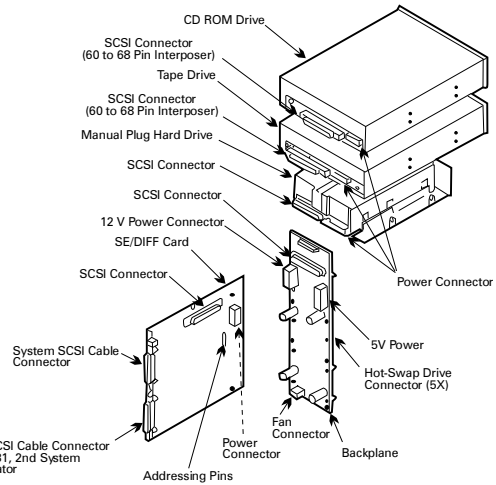

Internal SCSI Cable

When using single-ended cables to attach the 7131 to the system unit, the internal SCSI cable is mounted to the rear frame. In this configuration, the internal SCSI cable connects the external system SCSI cable to the manual-plug devices in the two media bays and to the backplane assembly.

When using differential cables to attach the 7131 to the system unit, the internal SCSI cable connects the optional SE/DIFF card to the manual-plug devices and to the backplane assembly.

Backplane Assembly

The backplane assembly contains the backplane and the hot-swap cage in a single Field Replaceable Unit (FRU). The backplane is a distribution board that connects the power supply cables and internal SCSI cable to the five hot-swap disk drive bays.

SE/DIFF Card

The SE/DIFF card converts differential SCSI signals to single-ended SCSI signals in order to support the manual-plug devices and hot-swap disk drives in the 7131. The optional SE/DIFF card allows the following configurations:

- Two systems connected to one 7131 tower
- Two systems connected to two 7131 towers
- One system connected to two 7131 towers
- One system connected to one 7131 with up to 25 meter SCSI bus length

Note: When two 7131 towers are chained together, both 7131s must have the optional SE/DIFF card installed.

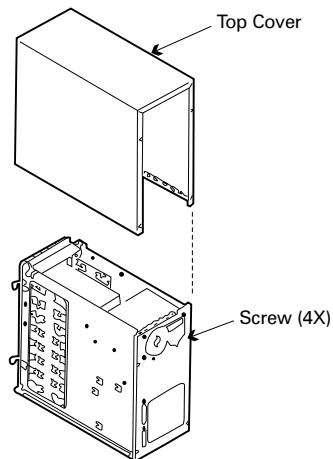

SCSI Device Address Settings

The 7131 supports up to seven SCSI devices. Hot-swap bays are numbered zero through four (0 - 4); the two media bays are numbered five and six (5 and 6). The SCSI device addresses for the hot-swap drives are set automatically in the 7131. All SCSI device address jumpers **MUST** be removed on any disk drives installed in the hot-swap bays.

Manual-plug devices installed in media bays five and six **MUST ALWAYS** have the SCSI device addresses set to five and six, respectively.

When the 7131 is connected to more than one system or is connected to another 7131, only six SCSI devices are supported in each 7131. Media bay six cannot be used when connecting multiple systems or 7131 towers. When two 7131 towers are connected together, the SCSI device addresses in the second 7131 are changed by an address jumper on the SE/DIFF card.

Device Address			
1 Tower 1 System	1 Tower 2 Systems	2 Towers and 1 or 2 Systems	
6	Not Available	Not Available	Not Available
5	5	5	13
4	4	4	12
3	3	3	11
2	2	2	10
1	1	1	9
0	0	0	8

Note: This information can also be found on a label that is attached to the front cover of the 7131.

SE/DIFF Card Address Settings

The jumper on the SE/DIFF card controls the SCSI device addresses in the 7131. When two 7131 towers are connected together the SE/DIFF address jumper must be moved in the second 7131. When this address jumper is moved, the device addresses in the second 7131 are changed to eight through thirteen (8 - 13), as illustrated below. Notice also that the second media bay, position six, cannot be used. It is important to remember this concept because even though the manual-plug device in media bay five is set to SCSI address five, the system will recognize the device as address thirteen.

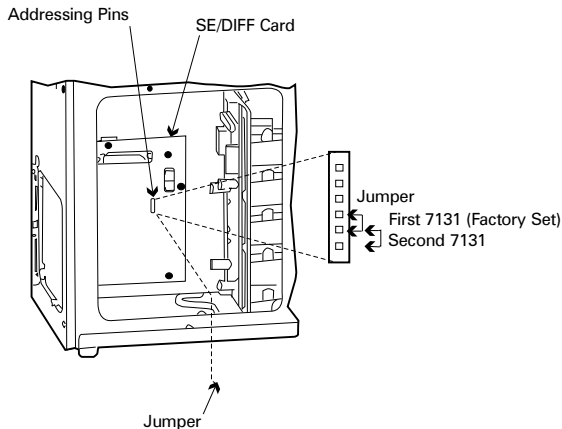

RS/6000 Support

The 7131 is attached to the RS/6000 via a SCSI-2 adapter. The SCSI-2 adapters supported include:

- SCSI-2 Fast/Wide Adapter/A (F/C #2415)
- SCSI-2 Differential Fast/Wide Adapter/A (F/C #2416 or F/C #2412)

Programming Support

The 7131 is supported on AIX 3.2.5 with additional PTFs, or on AIX 4.1.3 and later releases. The additional Version 3.2.5 PTFs are included on all AIX Version 3.2.5 orders shipped after May 19, 1995, labeled "AIX 3.2.5 Enhancement 5 (3250-05-00)."

Field Replaceable Units

Note: The following is a list of the key FRUs for the 7131. Please refer to the 7131 Service Guide for a complete list.

P/N	Description
05H4827	Internal SCSI Cable
87G4926	4GB/8GB 4mm Tape Drive
21H5151	5GB 8mm Tape Drive
8191148	Media Kit, 4GB/8GB 4mm Tape Drive incl.: 8191160 4mm Data Cartridge 8191146 4mm Diag. Cartridge 21F8763 4mm Cleaning Cartridge
59F3907	Media Kit, 5GB 8mm Tape Drive incl.: 21F8575 8mm Data Cartridge 21F8577 8mm Diag. Cartridge 21F8593 8mm Cleaning Cartridge
88G4921	600MB CD-ROM Drive
31F4232	Test CD, 600 MB CD-ROM
1675209	Address Jumper, 8mm Tape and CD-ROM Drive
74G7006	1.1GB Disk Drive
74G7007	2.2GB Disk Drive
74G7008	4.5GB Disk Drive
45G9800	Address Jumper, Disk Drive
06H7362	16-bit Power Carrier, Hot-Swap Disk Drive
06H7691	Address Cable, Disk Drive to Carrier
26H9180	Backplane Assembly (w/5 bay hot-swap cage)
27H0838	SE/DIFF Card
27H0956	Fan Assembly (incl. Isolators and Finger Guards)
61G8324	SCSI Terminator, Differential Fast/Wide
52G4291	0.6M SCSI Cable, DIFF 7131-7131 or System HA* attach
06G6036	1.0M SCSI Cable, DIFF 7131-7131 or System HA* attach
52G4337	1.5M SCSI Cable, DIFF System to 7131
52G9501	1.5M SCSI Cable, SE System to 7131
52G4233	2.5M SCSI Cable, DIFF 7131-7131 or System HA* attach
88G5749	4.5M SCSI Cable, DIFF 7131-7131 or System HA* attach
88G5747	12.0M SCSI Cable, DIFF 7131-7131 or System HA* attach
88G5748	14.0M SCSI Cable, DIFF 7131-7131 or System HA* attach
88G5746	18.0M SCSI Cable, DIFF 7131-7131 or System HA* attach
26H9205	Power Supply
92F0324	Interposer, 8-bit to 16-bit SCSI Device

* HA = High Availability. Used when connecting to Y-cable, P/N 52G4234

Documentation

SY27-7509 Service Guide
SA26-7003 Safety Information Manual
GC26-7095 User Guide (Includes Install Guide)

Note: *The documents listed above are shipped with the 7131.*

Customer Responsibilities

The 7131 is Customer Setup (CSU) and the customer is responsible for installing additional features (i.e., media devices, hard disk drives). The only feature that is a CE/CSR installed Miscellaneous Equipment Specification (MES) is the SE/DIFF card.

The customer is also responsible for ensuring that the appropriate actions have been taken to prepare a hard disk drive for replacement by a CE/CSR. These actions may include some or all of the following:

Document No.	Title
1895	Removing/Replacing a Fixed Disk
2580	When Fixed Disk Removed without Software Procedures

Copies of the two documents should be obtained and provided to customers, if necessary. Remember, the customers are responsible for protecting their data.

Maintenance Strategy

The hot-swap hard disk drives in the 7131 support concurrent maintenance and may be replaced with power on. The power must be removed from the 7131 before replacing the manual-plug devices in the two media bays.

*AIX, IBM, and RISC System/6000 are registered trademarks of International Business Machines Corporation.
RS/6000 is a trademark of International Business Machines Corporation.*

Backup data
Unmount filesystems
Remove filesystems
Remove paging space
Make a device unavailable to the operating system
Remove a disk from the volume group
Delete a device from the system configuration

To assist customers with the above activities, two documents are available from 1-800-IBM-4FAX (1-800-426-4329). These documents are:

IBM machine type: 7131

Tech Support 800-877-7764