

R

14.10

ARCNET® Local Area Network Driver LAND™

SECTION III

FEATURES

- Compatible with existing ARCNET® installations
- Compatible with ARCNET® coax drivers
- Pin Compatible with ARCNET® fiber-optic drivers
- Space saving economy
- 20 pin single in line package (SIP)
- Straight or right angle lead frame
- Built in filters for noise immunity
- Drives up to 2,000 ft. of Coax
- Replaces more than 25 discrete components and IC's

PIN CONFIGURATION

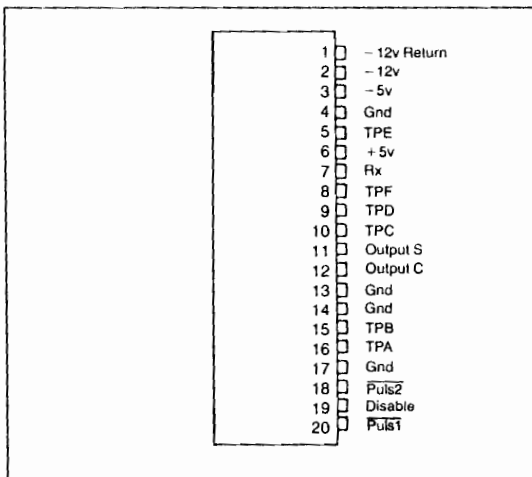

GENERAL DESCRIPTION

The HYC9068 is a Coax Driver for ARCNET Local Area Networks. The HYC9068 is compatible with SMC's COM9026/COM90C26 Local Area Network Controller (LANC) and the COM90C32 Local Area Network Transceiver (LANT). The HYC9068 simplifies network implementation while pro-

viding considerable space and cost savings plus the high reliability of a single component.

The HYC9068 contains both receive and transmit filters to guarantee interference-free data transfer over 2,000 ft. of RG-62 coaxial cable at 2.5 Mbps data rate.

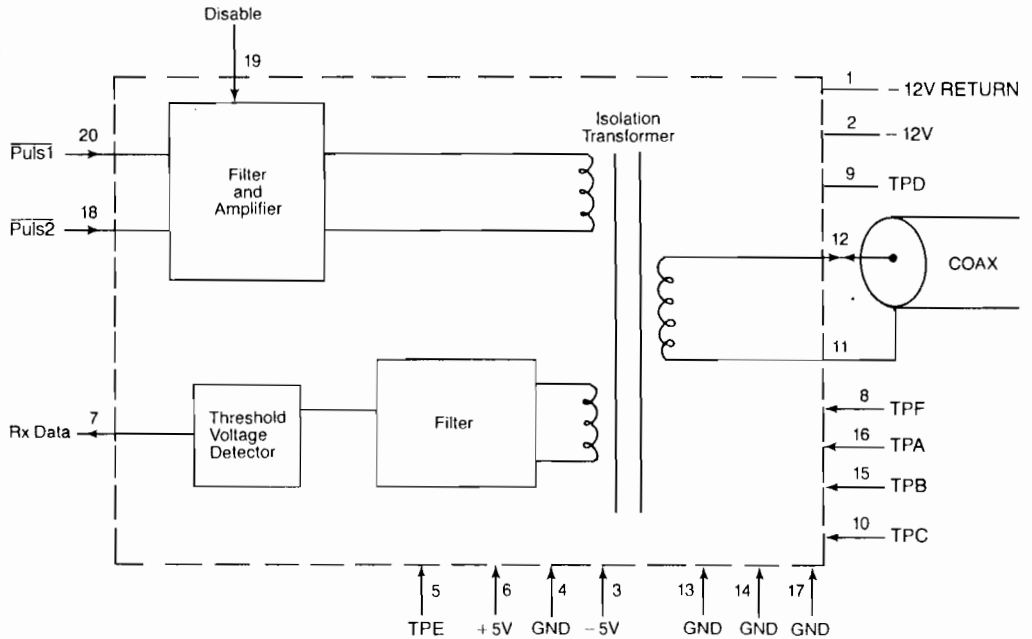

FIGURE 1—HYC9068-LAND BLOCK DIAGRAM

DESCRIPTION OF PIN FUNCTIONS

PIN #	NAME	SYMBOL	FUNCTION
1	-12V Return	GND	-12V Return
2	Power Supply	Vss	-12V Power Supply
3	Power Supply	VDD	-5 Volts Power Supply.
4, 13, 14, 17	Ground	GND	Ground
6	Power Supply	VCC	+ 5 Volt Power Supply.
7	Received Data Output	RX	Received Data, goes to RXIN of COM90C32 (TTL).
8, 10, 15, 16, 5, 9	Test Points	TPA, TPB, TPE TPD, TPC, TPF	Test Points. Make no connection to these pins.
11	COAX I/O	OUTPUT S	Connect to Coax Cable Shield (Outer Conductor). Bypass to GND is recommended.
12	COAX I/O	OUTPUT C	Connect to Coax Cable Inner Conductor (Center).
18	Pulse 2	$\overline{\text{PULS2}}$	TTL Level Input to the Transmitter Section (Active Low).
19	Disable	Disable	Normally connected to ground a high disables the transmitting.
20	Pulse 1	$\overline{\text{PULS1}}$	TTL Level Input to the Transmitter Section (Active Low).

FUNCTIONAL DESCRIPTION

The easiest way to create the optimum input is to use the SMC COM90C32 to provide PULS1 and PULS2. The DISABLE (Pin 19) should be grounded during normal

CABLE be bypassed to ground by a parameter adjustment (0.005 μ Fd/1Kv in parallel with two 5.6K ohm/1/2W resistors in series) as shown in typical interconnect diagram.

ELECTRICAL CHARACTERISTICS

MAXIMUM GUARANTEED RATINGS*:

Operating Temperature Range	0 C to + 70 C
Storage Temperature Range	- 40 C to + 125 C
Lead Temperature (soldering, 10 sec.)	+ 325 C
Positive Voltage on any pin with respect to Gnd	8 V
Negative Voltage on any pin except Vdd and Vss with respect to Gnd	- 0.3 V

*Stresses above those listed may cause permanent damage to the device. This is a stress rating only and functional operation of the device at these or at any other condition above those indicated in the operational sections of this specification is not implied.

NOTE: When powering this device from laboratory or system power supplies, it is important that the Absolute Maximum Ratings not be exceeded or device failure can result. Some power supplies exhibit voltage spikes or "glitches" on their outputs when the AC power is switched on and off. In addition, voltage transients on the AC power line may appear on the DC output. If this possibility exists it is suggested that a clamp circuit be used.

PRELIMINARY

Notice: This is not a final specification.
Some parametric limits are subject to change.

Electrical Characteristics Ta = 0 to 70 C, Vcc = + 5V \pm 5%, Vdd = -5V \pm 5%, or Vss = -12V \pm 5%

Parameter	Min.	Typ.	Max	Unit	Comments
INPUT VOLTAGE LEVELS					
Pulse 1, 2, DSBL inputs					
Low-level, VIL			0.8	V	Iil = -.8ma Iih = .2ma
High-level, VIH	2.0			V	
Received signal amplitude	6			Vp-p	
OUTPUT VOLTAGE LEVELS					
Rx Data output					
Low-level, VOL			0.4	V	One TTL load One TTL load
High-Level, VOH	2.4			V	
Transformer output	15.4	20		Vp-p	
Cable noise amplitude			4	Vp-p	
POWER SUPPLY CURRENT					
Icc			250	mA	
Idd			20	mA	
Iss			50	mA	
PULSE WIDTH					
Pulse 1, 2 inputs		100		nsec	
COAXIAL CABLE					
Type RG-62 (93 Ω)			2,000	ft	

SECTION III

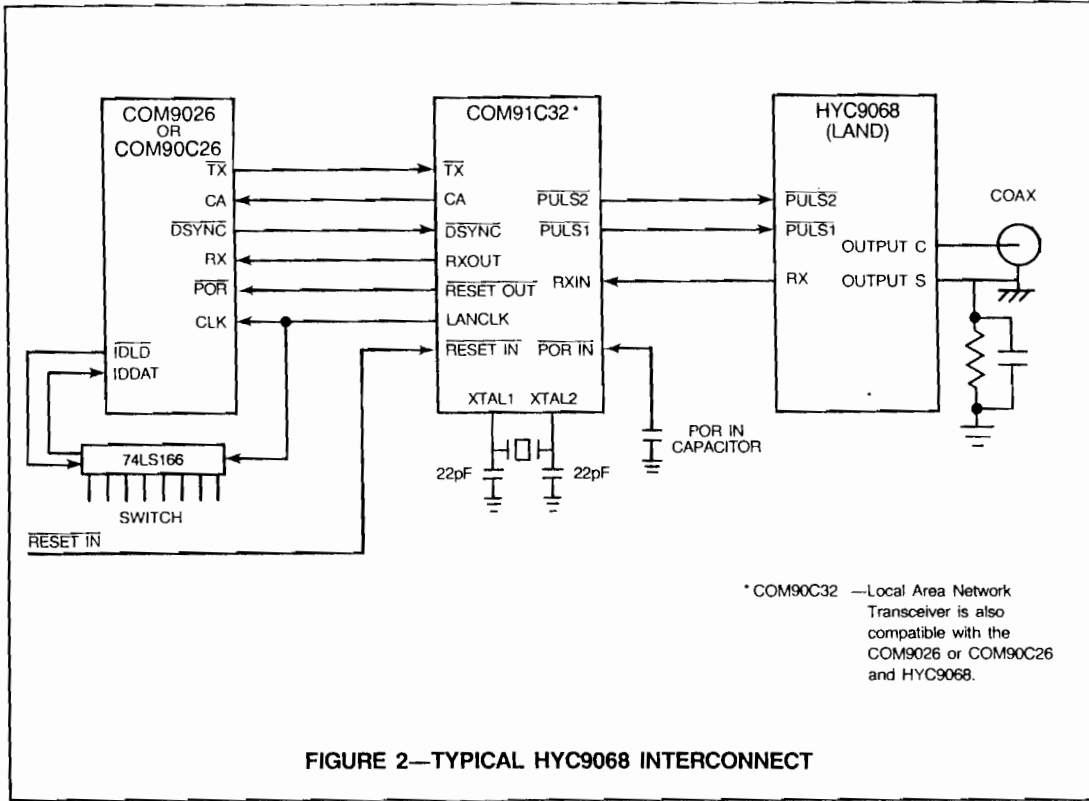

FIGURE 2—TYPICAL HYC9068 INTERCONNECT

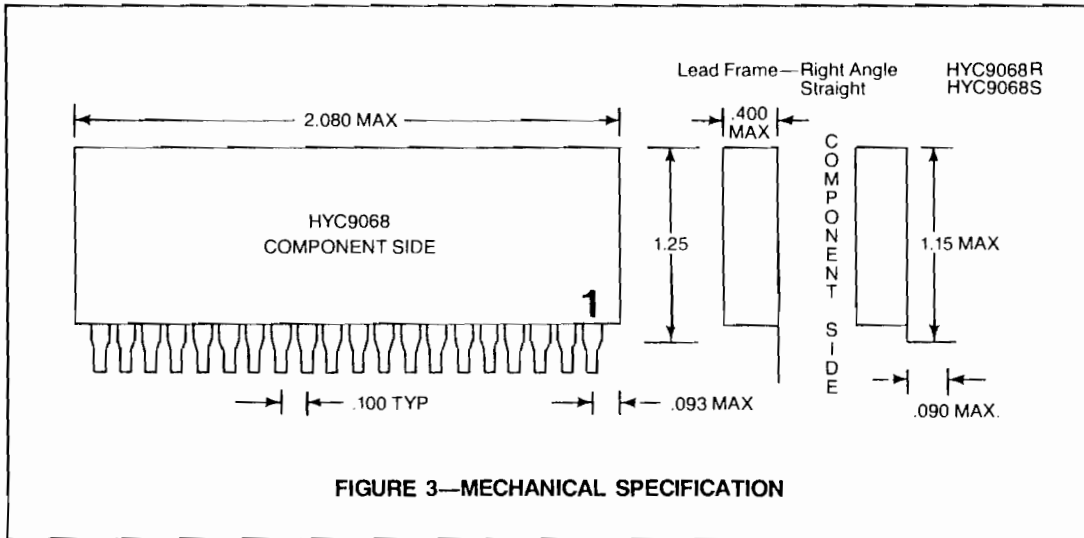

FIGURE 3—MECHANICAL SPECIFICATION

ARCNET* is a registered trademark of the Datapoint Corporation

STANDARD MICROSYSTEMS CORPORATION
 35 Marconi Blvd. Hingham, MA 01938
 (508) 773-3100 FAX (508) 771-8096

Circuit diagrams utilizing SMC products are included as a means of illustrating typical applications; consequent complete information sufficient for construction purposes is not necessarily given. The information has been carefully checked and is believed to be entirely reliable. However, no responsibility is assumed for inaccuracies. Furthermore, such information does not convey to the purchaser of the products described any license under the patent rights of SMC or others. SMC reserves the right to make changes at any time in order to improve design and supply the best product possible.