

IBM 6x86 MICROPROCESSOR  
 Sixth-Generation Superscalar  
 Superpipelined x86-Compatible CPU

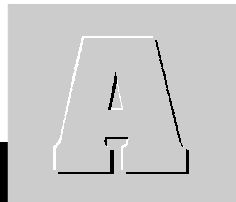

Appendix

Ordering Information for Module Revision Level “B” Only

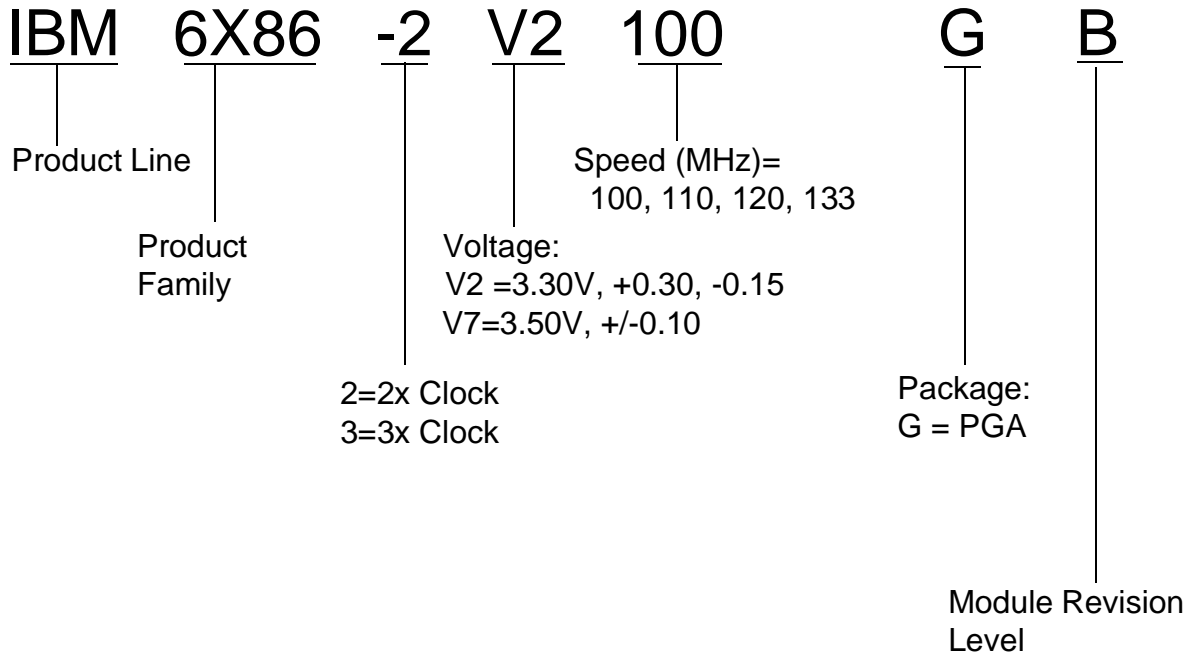

Table A-1. 6x86 Device to P-Rating Conversion

6x86 Frequency (MHz)		P-Rating
BUS	CORE	
50	100	P120+
55	110	P133+
60	120	P150+
66	133	P166+
75	150	P200+



## Ordering Information for Module Revision Level “C” and Later

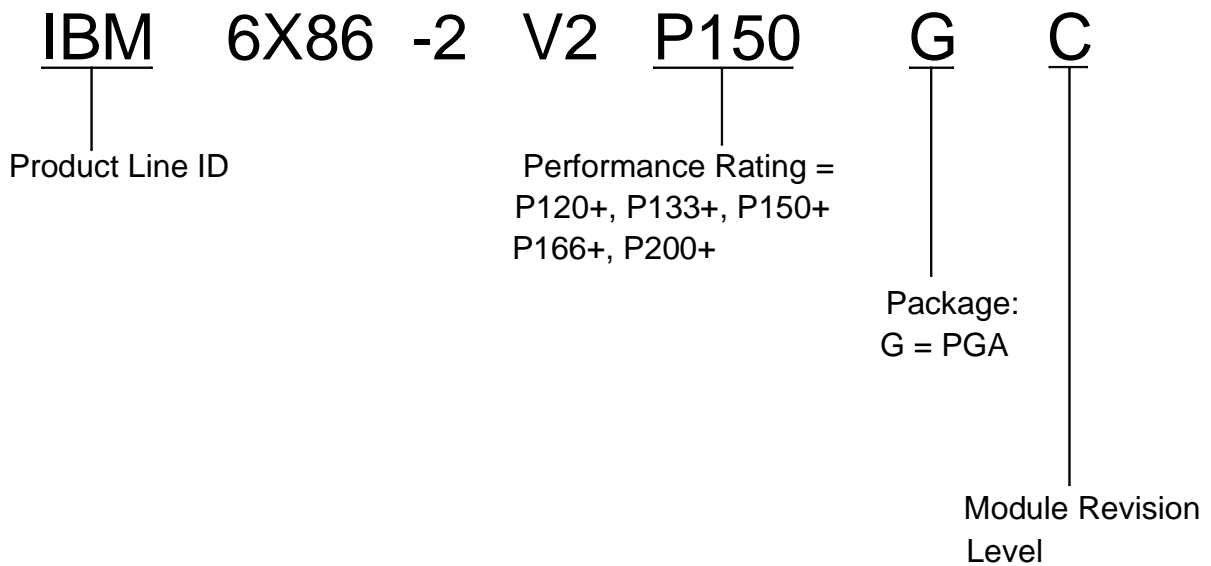

Table A-2. 6x86 Device to P-Rating Conversion

6x86 Frequency (MHz)		P-Rating
BUS	CORE	
50	100	P120+
55	110	P133+
60	120	P150+
66	133	P166+
75	150	P200+

For more information concerning the IBM 6x86 Microprocessor, please visit our website:  
<http://www.chips.ibm.com/products/x86/index.html> or call 1-800-IBM-3333.

## INDEX

“1+4” Burst Read Cycle	3-35	CCR5 Bit Definitions	2-30
<b>A</b> _____		Clock Control	3-7
AC Characteristics	4-5	Clock Count for CPU Instructions	6-13
Address Bus	3-9	Clock Count for FPU Instructions	6-29
Address Region Registers (ARRx)	2-31	Configuration Control Registers	2-23
Address Space	2-40	Control Registers	2-13
Architecture Overview	1-1	<b>D</b> _____	
<b>B</b> _____		Data Bus	3-10
Back-Off Timing	3-49	Data Bypassing	1-10
Branch Control	1-11	Data Forwarding	1-7
Burst Cycle Address Sequence	3-34	DC Characteristics	4-4
Burst Write Cycles	3-37	Debug Registers	2-37
Bus Arbitration	3-16	Descriptors	2-16
Bus Arbitration	3-46	Descriptor Table Registers and Descriptors	2-15
Bus Cycle Definition	3-11	Device Identification Registers	2-36
Bus Cycle Types	3-12	DIRx	2-36
Bus Cycles, Non-pipelined	3-29	<b>E</b> _____	
Bus Hold, Signal States During	3-17	Electrical Specifications	4-1
Bus Interface	3-1	Error Codes	2-62
Bus Interface Unit	1-16	EWBE# Timing	3-45
Bus State Definition	3-26	Exceptions	2-56
<b>C</b> _____		Exceptions in Real Mode	2-61
Cache Coherency Signals	3-18	<b>F</b> _____	
Cache Control	3-14	Flags Register	2-9
Cache Control Timing	3-43	Floating Point Unit	1-15
Cache Disable	2-34	FPU Error Interface	3-19
Cache Inquiry Cycles	3-50	FPU Operations	2-75
Cache Units	1-12	Functional Blocks	1-1
Caches, Memory	2-52	Functional Timing	3-25
CCR0 Bit Definitions	2-25	<b>G</b> _____	
CCR1 Bit Definitions	2-26	Gates and Protection	2-73
CCR2 Bit Definitions	2-27		
CCR3 Bit Definitions	2-28		
CCR4 Bit Definitions	2-29		



<b>I</b> _____		<b>O</b> _____	
I/O Address Space	2-41	Offset Mechanism	2-42
Initialization and Protected Mode	2-73	Out-of-order Processing	1-4
Initialization of the CPU	2-1	<b>P</b> _____	
Instruction Fields, General	6-2	Package, Mechanical Drawing	5-4
Instruction Line Cache	1-13	Paging Mechanisms (Detail)	2-45
Instruction Pointer Register	2-9	Paging Mechanisms (Introduction)	1-14
Instruction Set Overview	2-3	Paging - Traditional Mechanism	2-45
Instruction Set Encodings and Summary		Paging - Variable-Size Paging Mechanism	2-51
Instruction Set Summary	6-1	Pin Diagram, 296-Pin SPGA Package	5-1
Instruction Set Tables		Pin List, Sorted by Pin Number	5-2
Assumptions	6-12	Pin List, Sorted by Signal Name	5-3
Integer Unit	1-2	Pipeline Stages	1-3
Interrupt Acknowledge Cycles	3-41	Pipelined Bus Cycles	3-38
Interrupt and Exception		Power and Ground Connections	4-1
Priorities	2-59	Power Management Interface	3-22
Interrupt Control	3-13	Power Management Interface Timing	3-61
Interrupt Vectors	2-57	Privilege Level, Requested	2-8
Interrupts and Exceptions	2-55	Privilege Levels	2-71
<b>J</b> _____		Programming Interface	2-1
JTAG Interface	3-24	Protected Mode Address Calculation	2-44
<b>L</b> _____		Protection, Segment and Page	2-71
LBA#	2-35	Pull-Up and Pull-Down Resistors	4-1
Lines, within the Cache	2-53	<b>R</b> _____	
Lock Prefix	2-3	RAW Dependency Example	1-8
<b>M</b> _____		Recommended Operating Conditions	4-3
Maximum Ratings, Absolute	4-2	Region Control Registers (RCRx)	2-33
Memory Addressing	2-43	Register Renaming	1-4
Memory Addressing Methods	2-41	Register Sets	2-4
Memory Management Unit	1-14	Registers, Control	2-13
MESI States, Unified Cache	2-52	Registers, General Purpose	2-4
Mode State Diagram	2-70	Registers, 6x86 Configuration	2-23
<b>N</b> _____		Registers, System Set	2-11
NC and Reserved Pins	4-1	Requested Privilege Level	2-8
Non-pipelined Bus Cycles	3-29	Reset Control	3-7
		RESET Timing	3-25

<b>S</b> _____		Thermal Characteristics	5-6
Scatter/Gather Buffer Interface	3-19	Timing, Functional	3-25
Scatter/Gather Buffer		Translation Lookaside Buffer	2-45
Interface Timing	3-56	Translation Lookaside Buffer Testing	2-47
Sectors, Cache	2-53	<b>U</b> _____	
Segment Registers	2-7	Unified Cache	1-12
Selector Mechanism	2-44	Unified Cache Testing	2-53
Selectors	2-7	<b>V</b> _____	
Shutdown and Halt	2-69	Variable-Size Paging	
Signal Description Table	3-2	Mechanism	1-14
Signal Groupings	3-1	Variable-Size Paging	
SMI# Interrupt Timing	3-42	Mechanism	2-51
System Management Mode (SMM)	2-63	Virtual 8086 Mode	2-74
SMM Instructions	2-67	<b>W</b> _____	
SMM Memory Space	2-68	WAR Dependency Example	1-5
SMM Memory Space Header	2-65	WAW Dependency Example	1-6
SMM Operation	2-64	Weak Locking	2-34
Stop Grant (Special Bus Cycle)	3-12	Weak Write Ordering	2-34
Stop Grant and SUSP#	3-22	Write Gathering	2-35
Speculative Execution	1-12	Write Through	2-35
Suspend Mode, HALT Initiated	3-62		
Suspend Mode, Signal States During	3-23		
System Management Mode	2-63		
<b>T</b> _____			
Task Register	2-20		
Test Registers	2-39		
Testing of the Unified Cache	2-53		

**NOTICE TO CUSTOMERS:** Some of the information contained in this document was obtained through a third party and IBM has not conducted independent tests of all product characteristics contained herein. The product described in this document is sold under IBM's standard warranty.

The information contained in this document is subject to change without notice. The products described in this document are NOT intended for use in implantation or other life support applications where malfunction may result in injury or death to persons. The information contained in this document does not effect or change IBM's product specifications or warranties. Nothing in this document shall operate as an express or implied license or indemnity under the intellectual property rights of IBM or third parties. All the information contained in this document was obtained in specific environments, and is presented as an illustration. The results obtained in other operating environments may vary.

**THE INFORMATION CONTAINED IN THIS DOCUMENT IS PROVIDED ON AN "AS IS" BASIS. In no event will IBM be liable for any damages arising directly or indirectly from any use of the information contained in this document.**

© International Business Machines Corporation 1996.  
Printed in the United States of America  
2-96

All Rights Reserved

© Cyrix Corporation 1996.  
© IBM and the IBM logo are registered trademarks of the IBM Corporation.  
© Cyrix is a registered trademark of the Cyrix Corporation.  
IBM Microelectronics is a trademark of the IBM Corporation.  
6x86 is a trademark of Cyrix Corporation

Other company, product, and service names, which may be denoted by a double asterisk (\*\*), may be trademarks of service marks of others.

Product names used in this publication are for identification purposes only and may be trademarks of their respective companies.

IBM Corporation  
1000 River Street  
Essex Junction, Vermont 05452-4299  
United States of America