

Sony's Emotionally Charged Chip

Killer Floating-Point "Emotion Engine" To Power PlayStation 2000

by Keith Diefendorff

While Intel and the PC industry stumble around in search of some need for the processing power they already have, Sony has been busy trying to figure out how to get more of it—lots more. The company has apparently succeeded: at the recent International Solid-State Circuits Conference (see MPR 4/19/99, p. 20), Sony Computer Entertainment (SCE) and Toshiba described a multimedia processor that will be the heart of the next-generation PlayStation, which—lacking an official name—we refer to as PlayStation 2000, or PSX2.

Called the Emotion Engine (EE), the new chip upsets the traditional notion of a game processor. Whereas game CPUs have typically been cheap and wimpy compared with those in PCs, the EE is neither. At a whopping 240 mm² in a 0.25-micron process, the 10.5-million-transistor chip will cost more than \$100 to manufacture, according to our cost model. Never mind the companion 279-mm² rendering chip, called the graphics synthesizer (GS), or the I/O processor (IOP), which includes a complete first-generation PlayStation CPU for backward compatibility, as Figure 1 shows.

The EE and GS die sizes are frightening; vendors of PC processors break out in a cold sweat at the mere thought of a die larger than about 180 mm². How Toshiba and SCE intend to build two chips larger than that for a consumer game console is unclear. But the companies are intent on doing so; two large fabs are now being readied for just this purpose.

While the EE is not cheap, neither is it wimpy. The 300-MHz part packs a floating-point punch of 6.2 GFLOPS, three times that of Intel's top-of-the-line 500-MHz Pentium III with SSE (see MPR 3/8/99, p. 1) and 15 times that of a Celeron-400 (which lacks SSE). With the EE pumping out 75 million polygons per second and the GS drawing polygons at 2.4 billion pixels per second, the PlayStation 2000 will bring *Toy Story*-like realism to home games, says SCE.

PlayStation Rules

Since 1994, when it was first introduced, the PlayStation has amassed sales of 54 million units and has now reached a run

rate of two million units per month, making it the most successful single product (in units) Sony has ever built.

Although SCE has cornered more than 60% of the \$6 billion game-console market, it was beginning to feel the heat from Sega's Dreamcast (see MPR 6/1/98, p. 8), which has sold over a million units since its debut last November. With a 200-MHz Hitachi SH-4 and NEC's PowerVR graphics chip, Dreamcast delivers 3 to 10 times as many 3D polygons as PlayStation's 34-MHz MIPS processor (see MPR 7/11/94, p. 9). To maintain king-of-the-mountain status, SCE had to do something spectacular. And it has: the PSX2 will deliver more than 10 times the polygon throughput of Dreamcast, leaving it and other competitors in the virtual dust.

With DVD-ROM, Dolby Digital (AC-3) and Digital Theater System (DTS) sound, 32M of memory, a modem, IEEE-1394, and USB, the PSX2 system could be more than just a game console. Able to perform many of the functions for which people buy sub-\$600 PCs, the PSX2 has the potential to swipe a chunk of the low-end market from under the noses of PC vendors, x86 vendors, and Microsoft. The PSX2

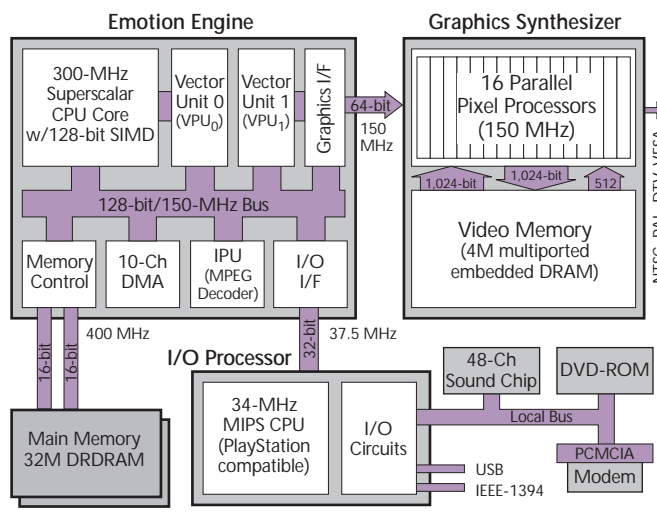

Figure 1. PlayStation 2000 employs an unprecedented level of parallelism to achieve workstation-class 3D performance.

could also throw a monkey wrench into the plans of dozens of Silicon Valley startups (such as VM Labs) working on DVD-based home-entertainment gizmos and could cut deeply into the market for WebTVs and similar devices—an event we have already forecast (see MPR 6/22/98, p. 3).

Totally New, But Still Backward Compatible

On its own merits, the PSX2 will be compelling enough to attract a large following. But to be safe, SCE will lure current customers to PSX2 by making it backward compatible with PlayStation. This compatibility will, it hopes, prevent the Osborne effect and avoid a drop in sales of PlayStation games to those anticipating the new platform, which won't arrive until 4Q99 in Japan and 3Q00 elsewhere. Lack of compatibility prevented previous game-console manufacturers from carrying momentum from one generation to the next.

SCE takes the brute-force approach to compatibility: it will simply include an identical copy of the PlayStation CPU in the new platform. So as not to waste silicon, this CPU serves as the PSX2's I/O processor when running new games, switching to the role of central processor to run old games. With this approach, the performance and quality of legacy games will be the same as on the original PlayStation.

Emotion Is the Difference

Although the EE provides conventional polygon-based rendering, it also supports more computationally complex curved surfaces, using NURBS-based (nonuniform rational B-splines) models, significantly boosting image quality. But much of the EE's compute power will go toward an even loftier goal: behavioral synthesis, or, as SCE calls it, emotion synthesis. This technology gives game programmers the ability to accurately model all manner of physical systems, allowing realistic behavior of characters and objects. For example, the system will enable lifelike facial expressions, as Figure 2 shows. The digital wind will ruffle hair and clothes. Gravity, mass, and friction will influence the motion of

objects. And the properties of materials such as water, wood, metal, and gas will all be accurately simulated.

Floating Point Key to Emotion

Making the vision of emotion synthesis a reality will require massive floating-point computational horsepower. To deliver these capabilities, the EE provides several autonomous processing units, as Figure 3 shows.

The EE chip itself includes a dual-issue superscalar core with 128-bit SIMD-integer capability and a scalar floating-point unit. This core is tightly coupled to a vector floating-point unit (VPU₀); together the core and VPU₀ run the game code and perform the high-level modeling computations. VPU₀ can also be pressed into service for 3D-geometry transformations when it is not otherwise occupied.

A second vector floating-point unit, VPU₁, is dedicated to 3D geometry and lighting. This unit runs independently, in parallel with the CPU, under microcode control. An autonomous image-processing unit (IPU) and a 10-channel DMA controller also operate in parallel with the CPU. All units pass graphics-display-list entries to the graphics interface (GIF), which prioritizes requests and passes them to the graphics synthesizer for rendering. All units connect through an on-chip shared 128-bit bus to a dual-channel Direct Rambus DRAM (DRDRAM) memory controller.

MIPS at the Core

The heart of the Emotion Engine is a superscalar RISC core with two 64-bit integer units and a single-precision scalar FPU. Although SCE and Toshiba in their ISSCC paper said the EE would operate at 250 MHz, SCE says the product will actually ship at 300 MHz. At that speed, the core achieves a Dhrystone 2.1 rating of 436 MIPS using the GNU C compiler.

Based primarily on the MIPS III (R4000) architecture, the core also includes many of the MIPS IV (R5000/R10000) instructions. But instead of the MIPS-standard MDMX 64-bit SIMD-integer instructions, SCE defined a completely new set of 128-bit SIMD-integer instructions. The 107 new instructions are implemented by doubling the width of the general-purpose registers to 128 bits and ganging together the two 64-bit integer units to process 128-bit-wide SIMD operands. Together, the two units can perform four 32-bit, eight 16-bit, or sixteen 8-bit integer arithmetic operations each cycle. SIMD instructions include add, subtract, multiply, divide, min/max, shift, logical, leading-zero count, 128-bit load or store, and 256-bit→128-bit funnel shift. SCE would not describe a few of the instructions for competitive reasons.

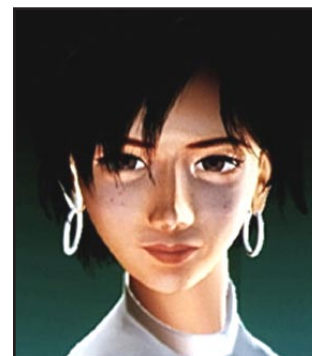

Figure 2. PlayStation 2000 screenshot. (Source: Namco)

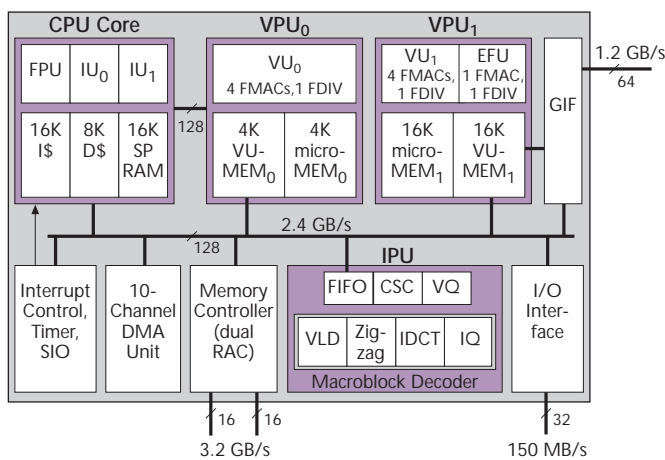

Figure 3. The PSX2's Emotion Engine provides ten floating-point multiplier-accumulators, four floating-point dividers, and an MPEG-2 decoder to deliver killer multimedia performance.

A 16K two-way set-associative instruction cache, an 8K two-way set-associative data cache, and a 16K (1K × 128-bit) scratchpad RAM (SPR) feed the core. The data cache is non-blocking, allowing hits to proceed while a miss is being serviced. Both the data cache and the SPR access in one cycle.

The SPR is provided to avoid thrashing the cache with long streams of continuous video addresses whose data is not reused within a video frame. Using the SPR as a double buffer, filled by the DMA, prevents video accesses from polluting the cache, making it more effective for other things.

A MIPS-compliant combined instruction/data TLB with 48 double entries (two physical page numbers selected by a low-order virtual-address bit) translates virtual addresses to physical addresses. The instruction and data caches are both virtually indexed and physically tagged with 64-byte lines. The SPR is logically in a separate memory space, enabled by an S-flag bit in the page-table entries.

The core can issue two instructions each cycle and, as Figure 4 shows, employs a simple in-order six-stage pipeline. Branch prediction is performed via a 64-entry branch-target-address cache (BTAC), which records the target address of taken branches, and a branch-history table (BHT) integrated into the instruction cache (two bits per line).

The BTAC is accessed in the first stage of the pipeline and, on a hit, provides a predicted target address on the next cycle. On a BTAC miss, the BHT, which is accessed in the instruction-fetch stage, is used to redirect instruction fetch, if necessary. Instructions are executed speculatively along the predicted path until the actual branch direction is resolved in the execute stage. If a branch is mispredicted, speculatively executed instruction results are discarded and the pipeline is restarted, imposing a three-cycle penalty.

Vector Units Provide Massive FP Power

VPU₀ is directly attached to the core by a 128-bit operand bus, with each VPU₀ macroinstruction executed as a MIPS coprocessor instruction. VPU₀ macroinstructions (e.g., matrix × vector multiply) are sequenced by microcode from a 4K SRAM instruction memory (microMEM₀). The second vector unit, VPU₁, runs asynchronously with the

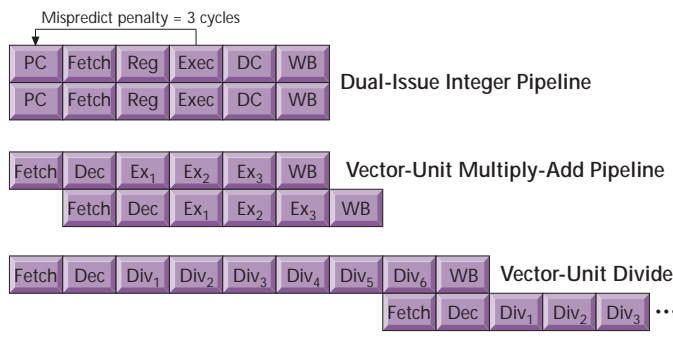

Figure 4. The EE's CPU uses a six-stage dual-issue pipeline. The vector units can each execute four single-precision floating-point multiply-accumulates every cycle, as well as one floating-point divide every seven cycles.

CPU, sequenced completely by microcode from its 16K instruction memory (microMEM₁). Each vector-unit microinstruction is a two-wide VLIW instruction, as Figure 5 shows.

Each vector unit has thirty-two 128-bit floating-point registers, sixteen 16-bit integer registers, and a local data memory. The data memory for VPU₀ (VUMEM₀) is 4K in size, while VUMEM₁ is 16K. Both VUMEMs can be read and written by the DMA controller. VUMEM₁ is connected directly to the GIF for rapid transmission of display lists to the GS.

Vector operands consist of four IEEE single-precision values that are distributed to the vector unit's four parallel multiply-accumulate units (FMACs). Each FMAC has a latency of four cycles and is fully pipelined for a throughput of one multiply-accumulate per cycle. The vector units each include one FP divider (FDIV) with a throughput of one divide (or square root) every seven cycles. VPU₁ also includes an elementary-function unit (EFU) for performing the scalar operations that go with 3D-geometry operations.

Image Processor Decodes MPEG-2

With DVD-ROM as the delivery medium, content providers will have from 8 to 28 times the storage capacity of PlayStation's CD-ROMs. This huge increase in capacity allows more complex, more sophisticated, and more realistic games, and it allows games to use high-quality video and sound.

Just as important, however, the DVD drive enables the playback of DVD movies, opening the potential for the PSX2 to serve that role in home-entertainment systems. While the PSX2 hardware has the capability to play DVD movies, SCE so far has refused to confirm that it will enable that feature. Although the company could be trying to avoid cannibalizing another Sony product, we expect that it will eventually come to the right decision and include the feature.

To decode the MPEG-2 compressed-video format used in DVD movies, the EE provides an autonomous image pro-

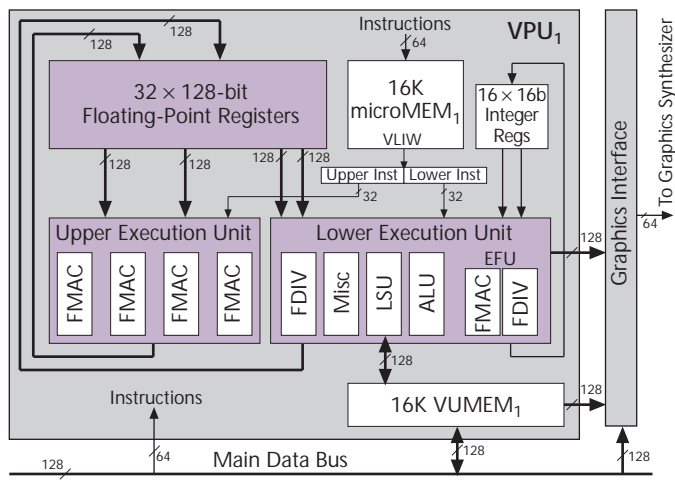

Figure 5. Each vector unit has enough parallelism to complete a vertex operation (19 mul-adds + 1 divide) every seven cycles.

cessing unit (IPU) that operates in parallel with the CPU. While decoding a video stream, the DMA controller feeds compressed video to the IPU's input FIFO over the internal data bus. The FIFO smooths out the data transfers, preventing the IPU from stalling while other transactions are on the bus.

The IPU can perform variable-length decoding (VLD), zigzag scanning, inverse quantization (IQ), and inverse-discrete-cosine transform (IDCT) operations, decoding MPEG-2 macroblocks at a rate of 768 cycles per macroblock (2.56 μ s/block). After macroblock decoding, the IPU performs color-space conversion (YCbCr to RGB), vector quantization, and 4 \times 4-ordered dithering. The IPU decompresses video at 150 Mpixels/s—fast enough even for HDTV.

In addition to its video-decoding duties, the IPU decompresses 3D-texture maps stored in main memory. The IPU performs on-demand texture decompression to either a high, medium, or low resolution, depending on the requirements of the image being rendered. The DMA controller transfers the decompressed video or texture data from the IPU's output FIFO over the internal data bus to the GIF.

Bandwidth Not Ignored

The internal data bus—the backbone connecting all of the EE's processing units to main memory and external peripherals—is 128 bits wide and operates at half of the CPU clock frequency. At a 300-MHz CPU speed, the bus provides a peak bandwidth of 2.4 GBytes/s. DMA transfers over this

bus occur in packets of eight 128-bit words, minimizing the protocol overhead. The bus achieves an efficiency of about 85%, leaving an effective bandwidth of about 2 GBytes/s.

The main-memory controller connects two channels of DRDRAM to the internal data bus. Although the two channels together can supply data at 3.2 GBytes/s, 33% faster than the internal bus can take it, buffering in the memory controller can make use of the extra bandwidth.

I/O interface circuits on the EE connect the internal data bus to an external 32-bit I/O bus, which transfers data between the EE and the I/O processor (IOP) at 37.5 MHz, one-eighth of the CPU frequency, as Table 1 shows. Although the bus could easily run faster, 150 MBytes/s of bandwidth is more than enough to carry all the I/O traffic from the DVD drive (1.5 MBytes/s), USB (up to 12 Mbits/s), IEEE-1394 (up to 400 Mbits/s), sound samples (up to 1.5 Mbytes/s), and a 56-Kbit/s V.90 modem. SCE will offer the modem on a PC Card (PCMCIA) in order to retain flexibility as communications technology evolves and also to deal with different regulations in different countries.

SCE has said little about the IOP other than that it is being designed jointly with LSI Logic and that its 32-bit MIPS-architecture core will be identical to the current PlayStation CPU, except for some minor enhancements to the cache and a 4 \times increase in DMA transfer rates. To achieve strict backward compatibility, the CPU will operate at 33.8 MHz, just like the original.

Emotion Engine	Description	Graphics Synthesizer	Description
Frequency	300 MHz	Frequency	150 MHz
CPU Core:	MIPS III, MIPS IV subset + 128b SIMD	Pixel Processing	16 parallel processors
Registers	32 \times 128-bit	Display List Bandwidth	1.2 GBytes/s
Microarchitecture	2-issue, two 64-bit integer units, 1 FPU	Video Memory:	4M multiported embedded DRAM
CPU Pipeline	6 stages	Bandwidth	48 GBytes/s (2,560-bit bus)
Instruction Cache	16K, two-way set-associative	Pixel Format	32-bit RGB α , 32-bit Z
Data Cache	8K, two-way set-associative	Rendering Performance:	75 Mpolygons/s peak
Scratchpad RAM	16K	48-Pix Quad w/Z,A	50 Mpolygons/s (2.4 Gpixels/s)
TLBs	48-entry combined instruction/data TLB	48-Pix Quad w/Z,A,T	25 Mpolygons/s (1.2 Gpixels/s)
Vector Unit 0:	4 FMACs, 1 FDIV	8 \times 8-Pixel Sprites	18.75 million/s
Memory	4K instruction, 4K data	Particles	150 million/s
Vector Unit 1:	5 FMACs, 2 FDIV	Output Process:	NTSC, PAL, VESA (1,280 \times 1,024 max)
Memory	16K instruction, 16K data	Size	0.25 μ m (0.25 μ m L ₃), 4-layer-metal
Image Processing Unit	MPEG-2 macroblock decoder	Package	279 mm ² , 42.7 million transistors
DMA	10 channels	I/O Processor	
On-Chip Bus Bandwidth	2.4 MB/s peak, 2.0 MB/s effective	Frequency	33.8 MHz or 37.5 MHz selectable
Main Memory:	32M, two DRDRAM channels	CPU:	MIPS (R3000 based)
Bandwidth	3.2 GBytes/s peak	Compatibility	PlayStation
Performance:		Characteristics	Enhanced cache, 4 \times PlayStation DMA
Floating-Point Peak	6.2 GFLOPS	I/O Bus to EE	150 MBytes/s, 32-bit bus
Perspective Transform	66 Mpolygons/s	Local-Bus Devices	DVD-ROM, PC Card, SPU2 sound chip
With Lighting & Fog	36 Mpolygons/s	IEEE-1394	100–400 Mbits/s
Bezier Surface Patches	16 Mpolygons/s	USB	1.5–12 Mbits/s
Image Decompression	150 Mpixels/s	SPU2 Sound Chip	
Process:	0.25 μ m (0.18 μ m L ₃), 4-layer-metal	Voices	48-channel + software voices on CPU
Size	240 mm ² , 10.5 million transistors	Sampling Rates	44.1 KHz or 48 KHz selectable
Power	15 W at 1.8 V		
Package	540-contact PBGA		

Table 1. The PlayStation 2000's four main chips offer the most impressive list of features ever in a consumer game console. (Source: SCE)

Vector Units Produce 66 Million Polygons/s

In both vector units, the latency of the divider is balanced with the throughput of the FMAC units so that, with three-stage software pipelining, each vector unit can achieve a throughput of one complete 3D-vertex operation (19 mul-adds + 1 divide) every seven cycles. At 300 MHz, with both vector units blazing, the EE can transform 66 Mpolygons/s. In contrast, a Pentium III-500 generates only 4 Mpolygons/s.

With lighting and fog effects applied, the EE's polygon throughput only drops to 36 Mpolygons/s, 18× the rate attained by a Pentium III-500. Even bandwidth-eating Bezier surface patches can be generated at 16 Mpolygons/s; as Table 2 shows, most other processors don't even handle Bezier patches, or do them too slowly to be useful.

GS Chip Guzzles 75 Million Polygons/s

The polygon display lists created by the EE's vector units are transferred by the GIF to the GS over a dedicated 64-bit bus at 150 MHz. At this clock rate, the graphics bus provides 1.2 GBytes/s of display-list bandwidth, more than twice that of 2× AGP and more even than 4× AGP.

The polygon-rendering ability of any graphics system is a strong function of the bandwidth between the pixel processor(s) and video memory. Not satisfied with the puny bandwidth that conventional 3D-rendering chips achieve with discrete SDRAM, SGRAM, or RDRAM memory, SCE integrated the video memory onto the same chip as the pixel engines. With this organization, the GS provides a monstrous 48 GBytes/s of bandwidth, 30 times more than is provided by the discrete 128-bit 200-MHz SGRAM video memory used on many high-end graphics systems today.

The GS's 4M of embedded multiport DRAM has a data-bus width of 2,560 bits, allowing simultaneous 1,024-bit video reads, 1,024-bit video writes, and 512-bit texture reads. The GS uses a 32-bit RGBα pixel format with a 32-bit Z value and supports the full gamut of rendering functions, including texture mapping, bump mapping, fogging, alpha blending, bi- and trilinear filtering, MIP mapping, antialiasing, and multipass rendering. The 4M memory is adequate to double

buffer an NTSC frame with full 32-bit color and Z buffering. The graphics synthesizer output supports NTSC, PAL, DTV, and VESA (1,280 × 1,024 maximum) formats.

Caution: 3D-Performance Claims Follow

Given the GS's extraordinary video-memory bandwidth and its 16 parallel pixel-processing engines, SCE boasts of a peak rendering rate of 75 Mpolygons/s and a pixel fill rate of 2.4 Gpixels/s for Gouraud-shaded, Z-buffered, and alpha-blended polygons. Adding texture cuts the fill rate in half to 1.2 Gpixels/s, or 25 million 48-pixel quadrilaterals per second. The PSX2 can also draw 19 million sprites/s (8 × 8 pixels) and 150 million particles/s (for smoke and spark effects).

PSX2's fully Z-buffered, alpha-blended, and textured drawing rate of 1.2 Gpixels/s is higher than those of even the newest round of PC 3D-game hardware (see MPR 4/19/99, p. 17). Voodoo3 from 3Dfx, for example, delivers 183 Mpixels/s, while Nvidia's RIVA TNT2 achieves 350 Mpixels/s. PSX2 also outpaces many graphics workstations, such as SGI's newest 500-MHz Pentium III-based NT workstation with a Cobalt graphics chip (the 320), which delivers about 150 Mpixels/s.

The 3D-graphics throughput of many systems, however, is held below their maximum rendering rates by the limited polygon-producing abilities of the CPU and by the bandwidth available to deliver polygon display lists to the rendering engine. By the time PSX2 ships in volume, Pentium III's speed could increase by nearly 50%, to 733 MHz, and AGP will have gone from the 2× to the 4× level (1 GByte/s). But even if these speedups fall straight through to drawing rates, which they won't, the PSX2 will still be 2–4× faster than the fastest PCs and many graphics workstations.

It should be noted, however, that the polygon rates quoted by 3D vendors tend to vastly overstate performance. In fact, some game developers have already expressed skepticism about SCE's performance claims for PSX2. Misled by the company's grossly exaggerated claims for the original PlayStation—which some claim are as much as a factor of five higher than the machine delivers in practice—developers are wary. Although SCE may be exaggerating its claims for the

Feature	Playstation 2000	Playstation	Nintendo 64	Dreamcast	PII-400	PIII-500	Gamma3
3D-Geometry Performance							
Peak GFLOPs	6.2 GFLOPs	Integer only	0.02 GFLOPs	1.4 GFLOPs	0.4 GFLOPs	2 GFLOPs	26 GFLOPs
Transformations (peak)	66 Mpoly/s	2 Mpolys/s	n/a	4 Mpoly/s	1.7 Mpolys/s	4 Mpolys/s	44 Mpolys/s
Transformations (real)	36 Mpolys/s	0.5 Mpolys/s	0.2 Mpolys/s	2 Mpolys/s	0.8 Mpolys/s	2 Mpolys/s	30 Mpolys/s
Bezier Surface Patches	16 Mpolys/s	None	None	None	Slow	Slow	None
3D-Rendering Performance							
					Voodoo3	TNT2	R4
Pixel Processing Engines	16	1	n/a	n/a	2	2	1
Simple Polygons (peak)	75 Mpolys/s	0.7 Mpolys/s	n/a	3 Mpolys/s	8 Mpolys/s	n/a	n/a
+ Z-Buffering & Alpha	2400 Mpixels/s	Simulated	n/a	n/a	183 Mpixels/s	350 Mpixels/s	125 Mpixels/s
+ Z, Alpha, & Texture	1200 Mpixels/s	34 Mpixels/s	n/a	n/a	183 Mpixels/s	350 Mpixels/s	125 Mpixels/s

Table 2. This table offers an indication of the PSX2's relative performance, although, since vendors do not adhere to any standard for measuring 3D-rendering rates, the numbers are not always directly comparable. The original PlayStation is integer only and offers only directional lighting, with no support for perspective, Z buffering, or bilinear filtering. Its polygon rates are somewhat higher than N64's, but N64 supports more rendering features, allowing fewer polygons to be used. N64 uses floating point for physics calculations only. The PSX2 will provide full-featured 3D rendering at higher performance than any other game console or PC. Only a high-end 3Dfx Gamma 3 with multiple R4 rendering chips (see MPR 11/16/98, p. 20) comes even close. n/a = not available. (Source: MDR estimates based on vendor data)

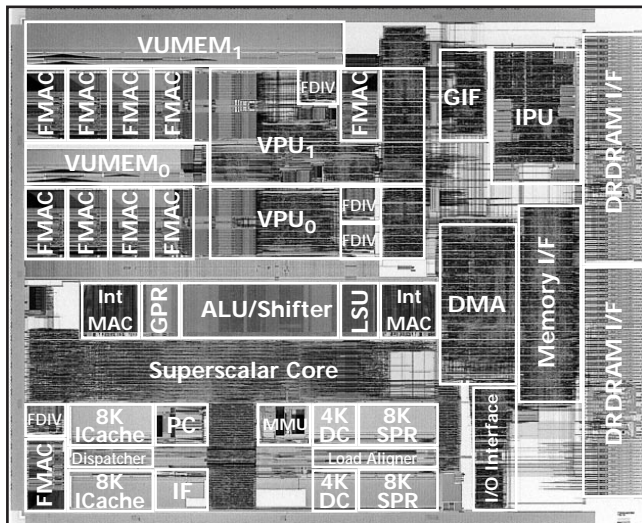

Figure 6. The Emotion Engine, heart of Sony's second-generation PlayStation, implements 10.5 million transistors and measures 17×14.1 mm in a 0.25-micron four-layer-metal 1.8-V process with 0.18-micron gates. (Source: SCE and Toshiba)

PSX2 as well, it, unlike the original PlayStation, is a serious piece of 3D hardware that seems to have the horsepower and bandwidth to back up SCE's claims. We see no reason to expect SCE's inflation factor to be any higher than that traditionally used by PC and workstation 3D vendors.

Workstation-Class 3D at Consumer Prices?

Without more complete information on how the PSX2's performance numbers were derived, their implications are impossible to evaluate. If the results turn out to have been obtained under ideal conditions (e.g., repeatedly calculating the same polygon), then the numbers, impressive as they are, indicate little about the platform's ultimate performance. But if the advertised rates can be sustained while forming real 3D objects, which SCE claims they can, the machine will indeed offer 3D performance well in excess of all current game consoles, high-end PCs, and even many graphics workstations.

On the basis of parallelism, bandwidth, and computational horsepower, we expect the PSX2 may indeed deliver this level of performance. What is less clear is whether SCE can deliver the chips at costs suitable for a consumer game console. The PlayStation debuted at \$299; it and the Nintendo 64 are both now selling for \$129, and Dreamcast is expected to sell for \$199. Considering PSX2's additional DVD function and its dramatically higher 3D performance, the PSX2 should command a premium. Indeed, if SCE delivers the PSX2 at \$299, life will become exceedingly miserable for Sega.

But unless SCE and Toshiba know something about manufacturing large die that the rest of the industry doesn't, \$299 is out of reach—at least initially. With 10.5 million transistors on 240 mm^2 of 0.25-micron silicon (as Figure 6 shows), the EE alone could cost \$130 to build, according to the MDR Cost Model. With 42.7 million transistors on 279 mm^2 (as Figure 7 shows), the GS will also cost about \$130 (assuming

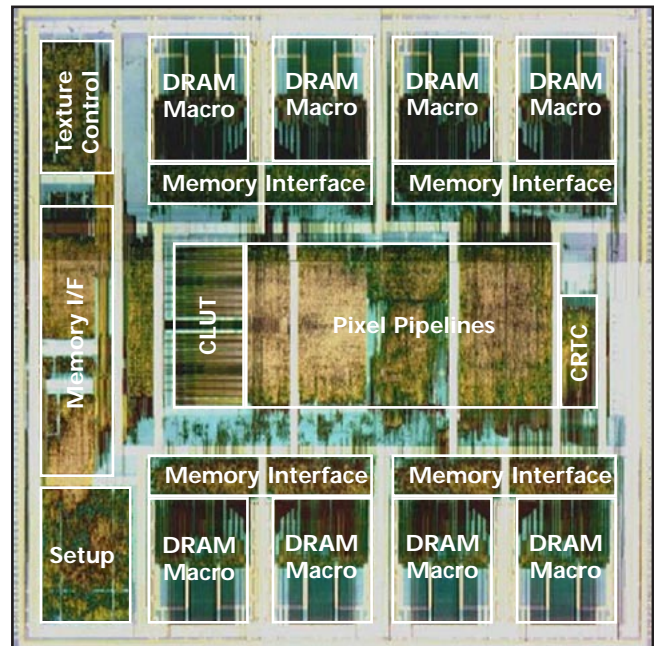

Figure 7. With 4M of multiported DRAM and 16 pixel processors, the 42.7-million-transistor graphics synthesizer is 16.7×16.7 mm in a 0.25-micron process with 0.25-micron gates. (Source: SCE)

DRAM redundancy is used to improve yield). Along with the costs of the other logic chips, the DRDRAMs, a fan to cool the 15-W Emotion Engine, and a DVD-ROM drive, the bill of materials will easily exceed \$299. Although game-console manufacturers do not expect much margin on the console (profits come from games), we still expect SCE to sell the game console initially for between \$400 and \$500.

At these costs, the chips were apparently designed in anticipation of process shrinks; presumably, SCE is prepared to suffer in the meantime. We expect the chips will be shrunk to a full 0.18-micron process before high volume is reached, lowering costs into the \$65 range—still high, but possibly enabling a \$299 system price. Further shrinks will be needed to bring costs in line with the current price of game consoles.

Surprisingly, SCE has no intention of taking advantage of the higher frequencies that come with shrinks—heresy for PC processor vendors. But SCE's view is that the game market—unlike the PC market—is entirely a software business; changes that could disrupt strict compatibility are unthinkable. In the consumer business, stability is what's paramount. Headroom gained from shrinks will go toward yield improvement (cost reduction), not performance.

Two Chips, Two Fabs

To build the EE, SCE is investing \$400 million in a joint venture with Toshiba to add new production lines to existing Toshiba clean-room facilities in Oita, Japan. These facilities will enter production this fall, with a planned capacity of 2,300 200-mm wafers per week. The companies plan to ramp production to two million chips per month—a feat that will require a shrink to 0.18 micron, according to our yield model.

In addition to the joint-venture facility with Toshiba, SCE itself is building another completely new fab in Nagasaki, to produce the GS. At a cost of nearly \$600 million, the new fab will have a capacity similar to that of the Toshiba facility and will enter production in the spring of 2000. In the meantime, the GS will be built in Sony's existing plant in Kokubu.

Dreamcast Reeling, But Not out Yet

A high price for PSX2 might give Sega some breathing room. Dreamcast is already available in Japan, and it will appear in the U.S. with more than 30 game titles by this Christmas. PSX2 hardware is nearly a year behind, and with development kits not yet broadly available, game developers will have to hustle to get titles ready by Christmas 2000—especially ones that take advantage of PSX2's new capabilities.

With a full year unopposed as the only next-generation console, and with the prospect of high prices for PSX2 looming, Dreamcast may yet survive. Still, PSX2 must be a nightmare for Sega executives, who had probably not anticipated such an aggressive play by SCE. Nintendo, whose next-generation Nintendo 2000 game console is still in development, was probably sent scurrying back to the drawing board by the strength of SCE's announcement.

It will be hard for competitors to match SCE's and Toshiba's manufacturing, PSX2's performance, and PlayStation's market momentum. Another important feature that competitors have no hope of matching is the PSX2's backward compatibility with a huge installed base of games. Dreamcast has already abandoned compatibility with Saturn, and Nintendo is saddled with ROM-based game cartridges—a technology that will not scale to the next generation.

Although the PlayStation 2000's two main chips are large, the level of performance they attain is nothing short of remarkable. This achievement is due to several factors, all of which stand in stark contrast to the direction in which Intel and other PC-processor vendors are moving. For one thing, SCE spent no effort or silicon to improve the performance of legacy code. For another thing, it wasted little on instruction-level parallelism. This decision is well advised, as the interesting parallelism in multimedia applications is data- and task-level parallelism, which are more efficiently exploited with SIMD, vector, and multiprocessor architectures.

Also, SCE spent no silicon on features like double- or extended-precision floating point, which add to cost but not to 3D performance. As a result of these decisions, SCE was able to create a chip with 10 single-precision FP multiplier-accumulators and four FP dividers—all of which contribute directly to 3D performance.

But PSX2's bleeding-edge technology has downsides. One that SCE must overcome is Direct Rambus DRAMs. Ken Kutaragi, CEO of Sony Computer Entertainment—widely known as the father of PlayStation—has publicly expressed his concern over the current state of DRDRAMs. But there aren't many alternatives: PC-133 SDRAM does not provide the needed bandwidth, and DDR SDRAMs are not yet stable.

Software: The Biggest Challenge

Possibly the largest technical hurdle facing SCE is enabling developers to take advantage of the EE's capabilities. Programming parallel machines is notoriously difficult. As the EE's superscalar-SIMD-vector-VLIW-MP structure raises parallelism to new heights, so too will it raise programming difficulty. SCE's only hope is that a rich set of libraries and a good software-development environment will make the problem tractable.

SCE has captured the imagination of game developers with early demonstrations of PSX2 hardware. To show off the platform's physics-modeling capability, for example, the company used a puff-ball demo in which the wind affects each strand of the puff-ball individually.

Big-name game developers Namco (www.namco.com) and Square (www.square.co.jp) have already presented technology demonstrations on PSX2 hardware. The platform provides exactly the features that Square needs for Final Fantasy VIII's finely rendered movie sequences. Anecdotal evidence so far suggests that simple ports of PlayStation games to PSX2 will be relatively easy and will get a big boost in realism. Rewriting to exploit PSX2's physics-modeling and rendering capabilities, however, will be more difficult, but also more rewarding.

SCE has already enlisted Animation Science (www.anisci.com) to develop middleware for modeling natural phenomena such as wind, rain, and snow. The company will port its Outburst particle animation and Rampage crowd-scene animation software to the PSX2. Math-Engine (www.mathengine.com) is also slated to provide software to model multibody dynamics and the behavior of fluids and deformable objects (e.g., bouncing rubber balls). It will also provide an artificial-intelligence layer to simulate running and jumping characters.

The aggressiveness of SCE's platform may signal the company's intention to move upscale from current game consoles, cutting a wider swath through the living room. Certainly, Internet access and DVD movies are within the scope of PSX2. And with USB, IEEE-1394, and PC Card interfaces, SCE has enabled other functions to be roped in. The new platform could even pose a threat to Wintel, as PSX2 can perform many of the functions of a home PC, given appropriate software. If, as some believe, the technology battles of the future will be waged over entertainment applications as opposed to business applications, PSX2 definitely improves Sony's position.

For now, SCE's sights are focused on the video-game market. Technically, the PlayStation 2000 is so far ahead of everything else that exists—or is likely to—that SCE isn't concerned about other game consoles. Instead, the company takes a broader view of competition; to it, the competition is everything else that competes for people's time. □