



---

# OEM FUNCTIONAL SPECIFICATIONS

for

**IBM-H2xxx-Sx (172/258/344 MB)**

**2.5-Inch Hard Disk Drive with SCSI Interface**

---

---





---

# OEM FUNCTIONAL SPECIFICATIONS

for

**IBM-H2xxx-Sx (172/258/344 MB)**

**2.5-Inch Hard Disk Drive with SCSI Interface**

---

**First Edition (December 1993)**

**The following paragraph does not apply to the United Kingdom or any country where such provisions are inconsistent with local law:** INTERNATIONAL BUSINESS MACHINES CORPORATION PROVIDES THIS PUBLICATION “AS IS” WITHOUT WARRANTY OF ANY KIND, EITHER EXPRESS OR IMPLIED, INCLUDING, BUT NOT LIMITED TO, THE IMPLIED WARRANTIES OF MERCHANTABILITY OR FITNESS FOR A PARTICULAR PURPOSE. Some states do not allow disclaimer or express or implied warranties in certain transactions, therefore, this statement may not apply to you.

This publication could include technical inaccuracies or typographical errors. Changes are periodically made to the information herein; these changes will be incorporated in new editions of the publication. IBM may make improvements and/or changes in the product(s) and/or the program(s) described in this publication at any time.

It is possible that this publication may contain reference to, or information about, IBM products (machines and programs), programming, or services that are not announced in your country. Such references or information must not be construed to mean that IBM intends to announce such IBM products, programming, or services in your country.

Requests for technical information about this product should be made to Storage OEM Engineering, Storage M & D, IBM Fujisawa, Japan.

IBM may have patents or pending patent applications covering subject matter in this document. The furnishing of this document does not give you any license to these patents. You can send license inquiries, in writing, to the IBM Director of Licensing, IBM Corporation, 208 Harbor Drive, Stamford, Connecticut 06904-2501, USA.

© Copyright International Business Machines Corporation 1993. All rights reserved.

Note to U.S. Government Users — Documentation related to restricted rights — Use, duplication or disclosure is subject to restrictions set forth in GSA ADP Schedule Contract with IBM Corp.

---

# Contents

<b>1.0 General</b>	1
1.1 Related Documents	1
1.2 References	1
<b>2.0 General Features</b>	3
<b>3.0 Drive Subsystem Description</b>	5
3.1 Control Electronics	5
3.2 Head Disk Assembly	5
<b>4.0 Drive Characteristics</b>	7
4.1 Formatted Capacity	7
4.2 Data Sheet	7
4.3 Performance Characteristics	7
4.3.1 Command Processing	8
4.3.2 Average Seek Time (Including Settling)	8
4.3.3 Single Track Seek Time	9
4.3.4 Full Stroke Seek	9
4.3.5 Average Latency	9
4.3.6 Drive Ready Time	9
4.3.7 Operating Modes	10
4.3.8 Throughput	10
<b>5.0 Data integrity</b>	11
5.1 Equipment Status	11
5.2 Write Safety	11
5.3 Data Buffer Test	11
5.4 Error Recovery	12
<b>6.0 Defect Flagging Strategy</b>	13
6.1 After Formatting	13
<b>7.0 Specifications</b>	15
7.1 Environment	15
7.1.1 Temperature and Humidity	15
7.2 DC Power Requirements	16
7.3 Reliability	16
7.3.1 Failure Rate	16
7.3.2 Mean Time Between Failures (MTBF)	16
7.3.3 MIL-HDBK 217E Calculation	16
7.3.4 Failure Rate Verification	16
7.3.5 Reliability Deliverable	16
7.4 Usage	17
7.5 Contact Start Stop (CSS)	17
7.6 Warranty	17
7.7 Useful Life	17
7.8 Preventive Maintenance	18
7.9 Data Reliability	18
7.10 Mechanical Specifications	18
7.10.1 Mechanical Dimensions	18
7.10.2 Mounting Hole Locations	19

7.10.3 Connector	20
7.10.4 Mounting Orientation	20
7.10.5 Landing Zone and Lock	20
7.11 Vibration and Shock	21
7.11.1 Operating Vibration	21
7.11.2 Non-Operating Vibrations	21
7.11.3 Operating Shock	22
7.11.4 Non-Operating Shock	22
7.12 Acoustics	22
7.12.1 Sound Power Levels	22
7.12.2 Sound Power Acceptance Criteria	23
7.13 Identification Labels	23
7.14 Electromagnetic Compatibility	24
7.15 Safety	24
7.15.1 Underwriters Lab (UL) Approval	24
7.15.2 Canadian Standards Authority (CSA) Approval	24
7.15.3 IEC Compliance	24
7.15.4 German Safety Mark	25
7.15.5 Flammability	25
7.15.6 Safe Handling	25
7.15.7 Environment	25
7.15.8 Secondary Circuit Protection	26
7.16 Packaging	26
<b>8.0 Electrical Interface Specifications</b>	<b>27</b>
8.1 Driver/Receiver	27
8.2 Connector	27
8.3 Signal Definition	28
8.3.1 Signal Line Descriptions	28
8.4 Cabling	29
8.5 Device Address	29
8.6 Signal Termination	29

# Figures

1. Operating Mode	10
2. Profile of IBM-H2344-S4, IBM-H2258-S3, and IBM-H2172-S2	19
3. 40-pin SCSI Connector	27
4. J1 Signal Assignment	28
5. J2 Signal Assignment	28





# Tables

1.	Formatted Capacity	7
2.	Data Sheet	7
3.	Performance Parameter	8
4.	Mechanical Positioning Performance	8
5.	Single Track Seek Time	9
6.	Full Stroke Seek Time	9
7.	Latency Time	9
8.	Drive Ready Time	9
9.	Process Speed	10
10.	DC Power Requirement	16
11.	Physical Dimension	18
12.	Random Vibration PSD Profile Breakpoints (Non-Operating)	21
13.	A-weighted Sound Power Levels	22



---

# 1.0 General

This document describes the characteristics of the following IBM 2.5-inch, SCSI interface hard disk drives:

- H2172-S2 (172MB, two R/W heads)
- H2258-S3 (258MB, three R/W heads)
- H2344-S4 (344MB, four R/W heads)

This document defines the hardware functional specifications. For details about the interface specifications, refer to the OEM Interface Specifications listed in section 1.1, “Related Documents” on page 1.

**Note:** MB in this document means 1,000,000 **bytes** and Mb means 1,000,000 **bits**.

---

## 1.1 Related Documents

- Interface Specifications
  - OEM Interface Specifications for IBM-H2xxx-Sx (172/258/344MB) 2.5-Inch Hard Disk Drive with SCSI Interface (SC18-2285).

---

## 1.2 References

- Safety:
  - IEC 380, 2nd Edition
  - IEC 435, 2nd Edition



---

## 2.0 General Features

The drives provide the following features.

- 172MB, 258MB, and 344MB formatted capacity (512 bytes/sector)
- 2.5-inch form factor
- SCSI-2 Interface
- MR (Magneto Resistive) Head Technology
- Integrated controller
- 1:1 Interleave
- 1,7 Run-Length Limited (RLL) Code
- Multi-zone Recording
- Enhanced ECC implementation
  - 128-bit Reed Solomon Code operating 10-bit symbol
  - Multi-burst On-The-Fly correction (up to four symbols in one sector)
- Automatic retry on read errors
- 64KB look ahead buffer
- Self-diagnostics during power up
- Media data transfer rate 19.8 to 31.9 Mb/second
- Synchronous and Asynchronous SCSI data transfer support
- SCSI data transfer capability is up to 4.5 MB/sec (Synchronous) and 3.0 MB/sec (Asynchronous)
- Average seek time of 14 milliseconds for read (Typical)
- Closed-loop actuator servo (Embedded Sector Servo)
- Rotary voice coil motor actuator
- Automatic Actuator lock
- Dedicated head landing zone
- All axis (6 directions) mounting permitted
- No preventive maintenance required
- 1.25 watts idle
- 17 mm Height



---

## **3.0 Drive Subsystem Description**

The subsystem descriptions are as follows.

---

### **3.1 Control Electronics**

The control electronics work with the following functions.

- SCSI-2 Interface Protocol
- Embedded Sector Servo
- 1,7 Run-Length-Limited (RLL) Code

---

### **3.2 Head Disk Assembly**

The following technologies are used for IBM-H2172-S2, IBM-H2258-S3, and IBM-H2344-S4.

- Sputtered disk
- MR head
- Multi-zone recording





---

## 4.0 Drive Characteristics

This chapter provides the characteristics of the drives.

---

### 4.1 Formatted Capacity

The customer usable data capacity is as follows.

Descriptions	IBM-H2172-S2	IBM-H2258-S3	IBM-H2344-S4
Bytes per sector	512	512	512
Total customer usable data bytes (MB)	172	258	344

---

### 4.2 Data Sheet

Media transfer rate	19.8– 31.9 Mb/sec
Interface transfer rate	4.5 MB/sec (Synchronous) 3 MB/sec (Asynchronous)
Data buffer size	64KB
Rotational speed	3800 RPM
Recording density (average)	74800 BPI
Track density	4300 TPI
Areal density (average)	322 Mb/sq. in.
Number of zones	8
Number of disks H2172-S2 H2258-S3 H2344-S4	1 2 2
Servo design method	Embedded sector servo

---

### 4.3 Performance Characteristics

The file performance is characterized by the following parameters:

- Command Overhead
- Mechanical Positioning
  - Seek Time
  - Latency

- Data Transfer Speed
- Buffering Operation

**Note:** All of the above parameters contribute to drive performance. Other parameters contribute to performance on the actual system. The following specification defines the drive characteristics, not the system throughput which is dependant on the system and the application.

The following table shows the **typical value** of each parameter. The detail descriptions are in the next sections.

Table 3. Performance Parameter	
Function	Typical
Seek time: Read	14 msec.
Seek time: Write	15 msec.
Rotational speed	3800 rpm
Power on ready (Typical)	2.7 sec.
Command overhead	4 msec.

### 4.3.1 Command Processing

Command overhead time is defined as the total time from when the command is received by the drive to the start motion of the actuator.

### 4.3.2 Average Seek Time (Including Settling)

Table 4. Mechanical Positioning Performance		
Command Type	Typical	Max.
Read	14 msec.	16 msec.
Write	15 msec.	17 msec.

“Typical” and “Max” for the performance specifications mean:

**Typical** Average of the drives tested at nominal environmental and voltage conditions.  
**Max** Maximum value measured on any one drive over the full range of the environmental and voltage conditions. (See 7.1, “Environment” on page 15 and 7.2, “DC Power Requirements” on page 16 for ranges.)

The seek time is measured from the start of actuator's motion to the start of a **reliable read or write operation**. Reliable read or write implies that error correction/recovery is not used to correct for arrival problems. The average seek time is measured as the weighted average of all possible seek combinations.

$$\text{Weighted average} = \frac{\sum_{n=1}^{\text{max}} (\text{max} + 1 - n) (\text{Tn.in} + \text{Tn.out})}{(\text{max} + 1) (\text{max})}$$

Where:

- max = Maximum seek length
- n = Seek length (1 to max)
- Tn.in = Inward measured seek time for a n track seek
- Tn.out = Outward measured seek time for a n track seek

### 4.3.3 Single Track Seek Time

Table 5. Single Track Seek Time		
Function	Typical	Max.
Read	4 msec.	5.5 msec.
Write	4 msec.	6.5 msec.

The single track seek time is the average of the seek time required to seek single track from every track inwards and outwards with a **random head switching**.

### 4.3.4 Full Stroke Seek

Table 6. Full Stroke Seek Time		
Function	Typical	Max.
Read	23.0 msec.	30.0 msec.
Write	24.0 msec.	31.0 msec.

Full stroke seek is measured as the average of 1000 full stroke seeks.

### 4.3.5 Average Latency

Table 7. Latency Time		
RPM	Time for a revolution	Average Latency
3800	15.8 msec.	7.9 msec.

### 4.3.6 Drive Ready Time

Table 8. Drive Ready Time		
Condition	Typical	Max.
Power On to Ready	2.7 sec.	9 sec.

- Ready**                    The condition in which the drive is able to perform a media access command (read, write) immediately.
- Power On**                This includes the time required for the internal self diagnostics.

### 4.3.7 Operating Modes

Spin-Up	This power ON mode is defined as the period of time from receipt power at the drive assembly or receipt of Start SCSI command, to Idle mode (or "Ready" state).
Idle	In this mode the disks are spinning at rated speed, the drive is able to accept and immediately execute commands requiring disk access. Actuator assembly is located on track in the "Ready" state.
Seek /Read/Write	This is a command execution mode where the drive actuator is moving or data is being written to or read from the media.
Note 1:	After power down or spindle stopped, a head locking mechanism secures the heads in the ID parking position.

Figure 1. Operating Mode

### 4.3.8 Throughput

Description	Typical
Command overhead	4 msec.
Average random seek time for read	14 msec.
Average random seek time for write	15 msec.
Disk to buffer data transfer	19.8– 31.9 Mb/sec.
Buffer to host data transfer (Note)	(Synchronous) Up to 4.5 MB/sec. (Asynchronous) Up to 3 MB/sec.

**Note:** Data transfer rate of buffer to host depends on the data transfer capability of the host system.

---

## 5.0 Data integrity

The drive retains recorded information under all non-write operations (seek, read, resets, power up/down) and is capable of detecting fault conditions associated with its own electrical or mechanical hardware to prevent loss of recorded or mis-recorded information during write operations. A SCSI BUS reset or a power down during a write operation does not result in a loss or mis-recording of more than one sector.

---

### 5.1 Equipment Status

Equipment status is available to the host system any time the drive is not engaged in reading, writing, or seeking. The status normally exists at power-on time and remains until the following events occur.

- Access recalibration/tuning is completed.
- Spindle speed meets requirements for reliable operation.
- Self-check of drive is complete.

Appropriate error status is made available to the host system if any of the following occurs after the drive has become ready:

- Spindle speed goes outside of requirements for reliable operation.
- “Write fault” is detected.

---

### 5.2 Write Safety

The verification of write operations involves a read-back check of the CRC or ECC in conjunction with **write fault** detection circuits. The **write fault** detection circuits reveal conditions where a write operation was intended but did not occur correctly and the CRC or ECC verification occurred for old information, or cases where data is erroneously erased.

---

### 5.3 Data Buffer Test

The data buffer is tested at a power-on-reset and when a drive self-test is requested by the host. The tests for write/read use a X'00' and X'ff' pattern on the whole buffer.

---

## 5.4 Error Recovery

Errors occurring with the drive are handled by the error recovery procedure.

Errors that are uncorrectable after application of the error recovery procedures are reported to the host system as non-recoverable errors.

## 6.0 Defect Flagging Strategy

Media defects are remapped to the next available sector during a format operation. The mapping from RBA to the physical location is calculated by an internally maintained table.

### 6.1 After Formatting

- Data areas are optimally used after the drive is formatted.
- A spare sector is located on each track spread on the user data area.

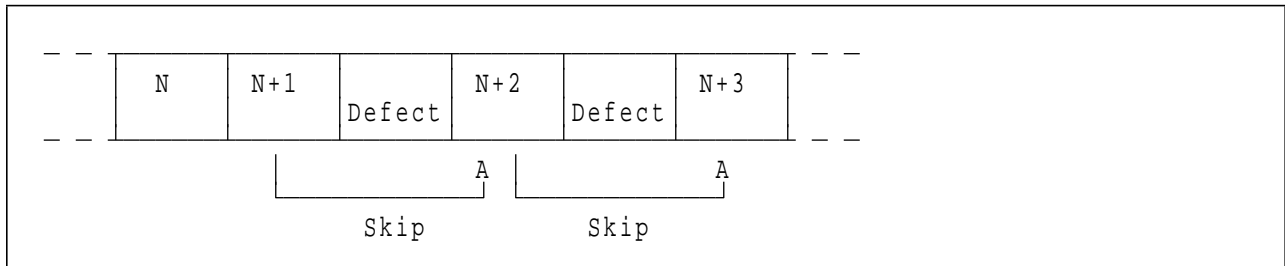

Defects are skipped without any constraint, such as track or cylinder boundary.





## 7.0 Specifications

This chapter provides the specifications of the drives.

### 7.1 Environment

#### 7.1.1 Temperature and Humidity

<b>Operating Conditions</b>	
Temperature	5 to 55°C (See note)
Relative Humidity	8 to 90 % non-condensing
Maximum Wet Bulb Temperature	29.4°C non-condensing
Maximum Temperature Gradient	20°C
Altitude	- 152 to 3048 m
<b>Shipping Conditions</b>	
Temperature	- 40 to 65°C
Relative Humidity	5 to 95 % non-condensing
Maximum Wet Bulb Temperature	40°C non-condensing
Maximum Temperature Gradient	20°C / Hour
Altitude	- 152 to 4572 m
<b>Storage Conditions</b>	
Temperature	0 to 65°C
Relative Humidity	5 to 95 % non-condensing
Maximum Wet Bulb Temperature	40°C non-condensing
Maximum Temperature Gradient	20°C / Hour
Altitude	- 152 to 4572 m
<b>Note:</b>	
The system is responsible to provide sufficient ventilation to maintain a surface temperature below 60°C at the center of the top cover of the drive.	

---

## 7.2 DC Power Requirements

Power	Requirement	Note
Nominal supply	+ 5 V	
Power supply ripple (0– 20 MHz)	100 mV p-p max.	1
Tolerance	± 5 %	2
Supply Current	Mean value	
Idle (average)	0.27 A RMS	
Read / write	0.56 A RMS	
Seek (average)	0.40 A RMS	
Start up (peak)	0.94 A RMS	
Supply rise time	7– 100 ms	

### Notes:

1. The maximum ripple is measured at 5 V input to the drive.
2. The drive does not incur damage by an over-voltage condition of +25% and the maximum duration is less than 20 milliseconds on the 5 V nominal supply.

---

## 7.3 Reliability

The following is the reliability information.

### 7.3.1 Failure Rate

The failure rate is less than 3.3 fails per million device-hours of operation.

### 7.3.2 Mean Time Between Failures (MTBF)

300,000 power-on hours (POH).

### 7.3.3 MIL-HDBK 217E Calculation

The MIL-HDBK 217E Calculation method was used partially to estimate the MTBF of electrical parts.

### 7.3.4 Failure Rate Verification

The verification of the failure rate is to be covered by verification tests in IBM.

### 7.3.5 Reliability Deliverable

The testing for reliability is to be covered by verification tests in IBM.

---

## 7.4 Usage

Total power-on hours with minimum power on/off cycles for desk top computers.

- 43,200 hours for 5 years
- 50 power-on/off cycles per month
- 720 power-on hours per month
- Seeking/reading/writing rate of 20% of power-on hours

Total power on hours with minimum power on/off cycles for notebook computers.

- 6,600 hours for 5 years
- 1,000 power-on/off cycles per month
- 110 power-on hours per month
- Seeking/reading/writing rate of 50% of power-on hours

---

## 7.5 Contact Start Stop (CSS)

The drive meets the specified error rates after the following start/stop or power on/off cycles in the environment.

- 52,000 cycles under the temperature of 40°C and 15– 20% humidity.
- 10,400 cycles under the temperature of 55°C and 8– 15% humidity.

---

## 7.6 Warranty

The warranty will be covered by contracts.

---

## 7.7 Useful Life

The useful life of the drive is 5 years minimum.

---

## 7.8 Preventive Maintenance

None.

---

## 7.9 Data Reliability

- Probability of not recovering data ..... 1 in 10E13 bits read
- ECC implementation  
128-bit Non-interleave Reed Solomon Code operating 10-bit symbol is used to cover the data fields.  
On-The-Fly correction covers up to four symbols of error in one sector.  
Off-line correction covers up to five symbols of error in one sector.

---

## 7.10 Mechanical Specifications

### 7.10.1 Mechanical Dimensions

The following chart describes the dimensions for the 2.5-inch hard disk drive form factor by model.

<b>Dimension</b>	<b>IBM-H2172-S2</b>	<b>IBM-H2258-S3</b>	<b>IBM-H2344-S4</b>
Height (mm)	17.0 +0.35/-0.3	17.0 +0.35/-0.3	17.0 +0.35/-0.3
Width (mm)	70.0 ± 0.25	70.0 ± 0.25	70.0 ± 0.25
Length (mm)	100.0 ± 0.25	100.0 ± 0.25	100.0 ± 0.25
Weight (gram)	180 Max.	180 Max.	180 Max.

## 7.10.2 Mounting Hole Locations

Figure 2 shows a profile of the drive which includes the mounting hole locations.

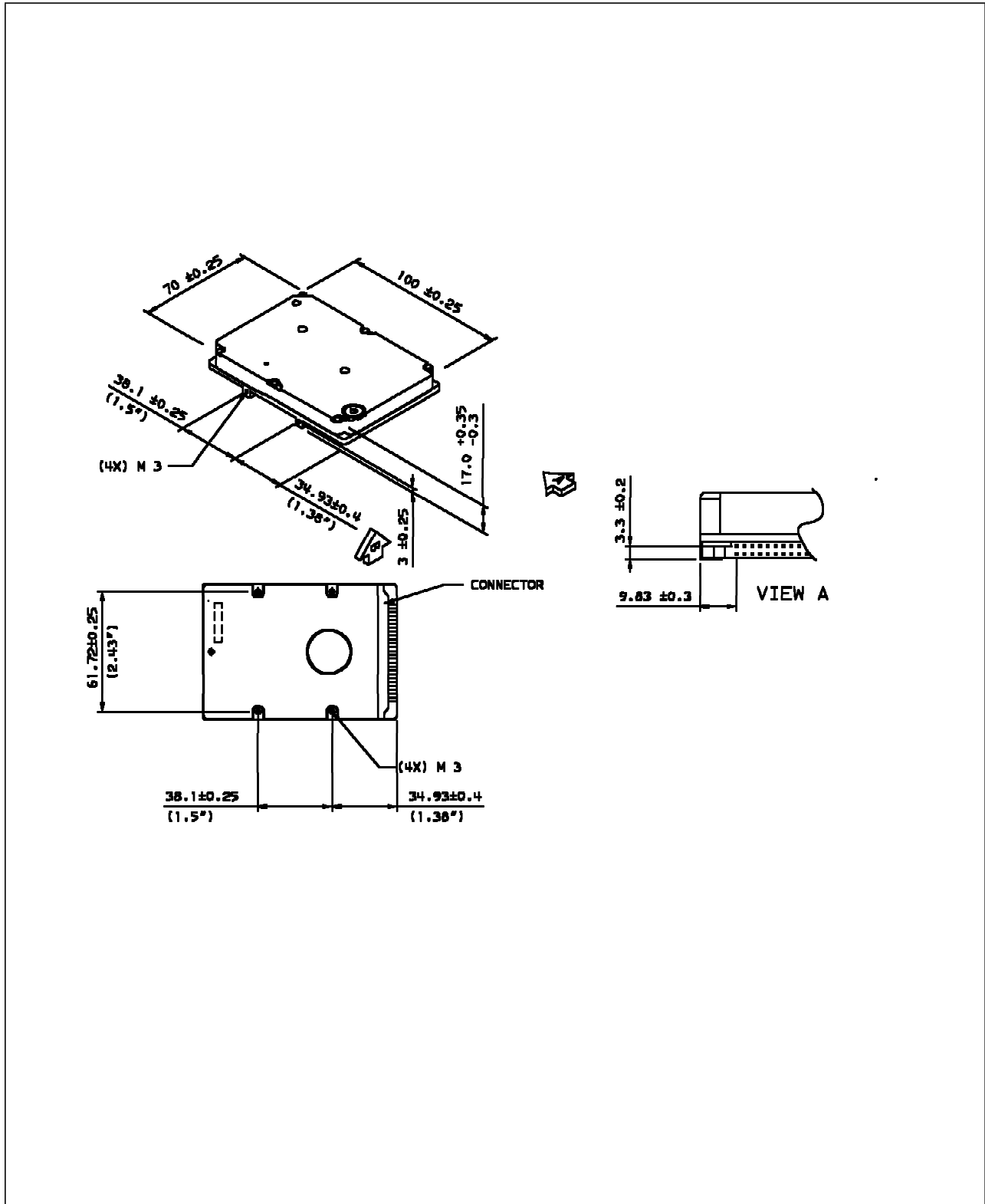

Figure 2. Profile of IBM-H2344-S4, IBM-H2258-S3, and IBM-H2172-S2

### **7.10.3 Connector**

Connector specifications are described in section 8.0, “Electrical Interface Specifications” on page 27.

### **7.10.4 Mounting Orientation**

The drive operates in all axes (6 directions). The drive operates within the specified error rates when tilted  $\pm 5$  degrees from these positions.

Performance and error rate stay within specification limits even if the drive is operated in other orientations from which it was formatted. Thus a drive formatted in the horizontal orientation operates in the vertical position without any degradation, and vice versa.

The recommended mounting screw torque is  $3 \pm 0.5$  Kgf.cm. The recommended screw depth is  $3.5 \pm 0.5$  millimeters for bottom mounting and  $5.0 \pm 0.5$  millimeters for horizontal mounting.

The system is responsible for mounting the drive securely enough to prevent excessive motion or vibration of the drive at seek operation or spindle rotation, using appropriate screws or equivalent mounting hardware. Consult the issuer of this specification for actual application.

The vibration test and the shock test are to be conducted with the drive mounted to the table using four bottom screws.

### **7.10.5 Landing Zone and Lock**

A landing zone on the disk, not the data area of the disk, is provided to protect the disk data during shipping, movement, or storage. After power down, a head locking mechanism secures the heads in this zone.

## 7.11 Vibration and Shock

All vibration and shock measurements in this section are made with the drive that has no mounting attachments for the systems. The input power for the measurements is applied to the normal drive mounting points.

### 7.11.1 Operating Vibration

The drive operates with no non-recoverable errors while being subjected to the following vibration levels.

The measurements are carried out during 30 minutes of random vibration using the power spectral density (PSD) levels specified in IBM standards as V5L. The vibration test level for V5L is 0.67G (RMS).

#### Random Vibration PSD Profile Breakpoint

5 Hz	2.0 x E-5	g**2/Hz
17 Hz	1.1 x E-3	
45 Hz	1.1 x E-3	
48 Hz	8.0 x E-3	
62 Hz	8.0 x E-3	
65 Hz	1.0 x E-3	
150 Hz	1.0 x E-3	
200 Hz	5.0 x E-4	
500 Hz	5.0 x E-4	

The specified levels are measured at the mounting points.

### 7.11.2 Non-Operating Vibrations

The drive does not sustain permanent damage or loss of recorded data after being subjected to the environment described below.

#### 7.11.2.1 Random Vibration

The test consists of a random vibration applied in each of three mutually perpendicular axes with the time duration of 15 minutes per axis. The PSD levels for the test simulates the shipping and relocation environment which is shown below.

Table 12. Random Vibration PSD Profile Breakpoints (Non-Operating)							
Hz	Random Vibration PSD Profile Breakpoints (Non-Operating)						
Hz	2	4	8	40	55	70	200
G**2/Hz	0.001	0.03	0.03	0.003	0.01	0.01	0.001

Overall RMS (Root Mean Square) level of vibration is 1.04G (RMS).

### 7.11.2.2 Swept Sine Vibration

- 2 G (Zero to peak), 5 to 200 to 5 Hz sine wave
- 0.5 oct/min sweep rate
- 15 minutes dwell at two major resonances

### 7.11.3 Operating Shock

The drive meets the following criteria.

- No data loss, seek errors, or permanent damages within shock pulses of 10G, 11 ms half-sine wave.
- No data loss or permanent damages at Idle, Seek and Read modes within shock pulses of 60G, 3.5 ms half-sine wave.

The shock pulses of each level are applied to the drive, five pulses in each direction and in all three axes. There must be a minimum of a 3 seconds delay between each shock pulse. The input level is applied to the base plate where the drive is attached with four screws.

### 7.11.4 Non-Operating Shock

The drive withstands, without damage or degradation of performance, a 120G half-sine wave shock pulse of 11 ms duration and a 250G half-sine wave shock pulse of 2 ms duration on six sides when heads are parked. (When the power is not applied to the unit, the heads are automatically located on the parked position.)

All shocks are applied in each direction of the drive three mutually perpendicular axes, one axis at a time. Input levels are measured at the frame of the hard disk drive.

---

## 7.12 Acoustics

The following shows the acoustic levels.

### 7.12.1 Sound Power Levels

The upper limit criteria of the A-weighted sound power levels are given in bels relative to one pico watt and are shown in the following table.

Mode	A-weighted Sound Power Level (Bel)
Idle	4.5
Operating	4.8

Background power levels of the acoustic test chamber for each octave band are to be recorded.

Sound power levels are measured with the drive supported by spacers so that the lower surface of the drive is located  $25 \pm 3$  mm height from the chamber floor. No sound absorbing material is used.

The acoustical characteristics of the drive subsystem are measured under the following conditions.



Idle mode:

Powered on, disks spinning, track following, unit ready to receive and respond to control line commands.

Operating mode:

Continuous random cylinder selection and seek operation of actuator with a dwell time at each cylinder. Seek rate for the drive can be calculated as shown below.

$$\text{Dwell time} = (0.5 + N) \times 60/\text{RPM}$$

$$\text{Seek rate} = 1/(\text{Average seek time} + \text{Dwell time})$$

Where N = number of maximum data surfaces (N=4 for H2344-S4)

## 7.12.2 Sound Power Acceptance Criteria

Statistical upper limit  $(L_{W_{\text{oct}}})_{\text{stat}}$  is calculated with the following formula.

$$(L_{W_{\text{oct}}})_{\text{stat}} = (L_{W_{\text{oct}}})_{\text{m}} + k \times (s_t)_{W_{\text{oct}}}$$

where:

$(L_{W_{\text{oct}}})_{\text{m}}$  is the mean value of the sound power level for samples of N drives.

$(s_t)_{W_{\text{oct}}}$  is the total standard deviation for sound power level at each octave band.

$$(s_t)_{W_{\text{oct}}} = \text{SQRT}((s_R)_W^2 + (s_P)_{W_{\text{oct}}}^2)$$

$(s_R)_W$  is the standard deviation of reproducibility for sound power level.

Assume  $(s_R)_W = 0.075$  B.

$(s_P)_{W_{\text{oct}}}$  is the standard deviation of the samples for sound power level at each octave band.

k is a coefficient determined by number of samples (N) as shown below.

N	3	4	5	6	7	8	9	10	11	12	13	14	15
k	3.19	2.74	2.74	2.49	2.33	2.22	2.13	2.07	2.01	1.97	1.93	1.90	1.87

The calculated left-hand side of the criterion equation above is referred to as LWU and rounded to the nearest 0.05 bel. The individual terms may be rounded to the nearest 0.01 bel before calculation.

---

## 7.13 Identification Labels

The following labels are affixed to every drive.

1. A label placed on the top of the HDA contains the statement “Made by IBM” or equivalent, Part number, and MLC number.
2. A bar code label placed on the disk drive is based on user request. The location is to be designated in the drawing.
3. Labels containing the vendor's name, disk drive model number, serial number, place of manufacture and UL/CSA logos.

Except for the bar code, the labels may be integrated.

---

## 7.14 Electromagnetic Compatibility

The drive, when installed in the host system and exercised with a random accessing routine at maximum data rate, meets the worldwide EMC requirements listed below.

IBM will provide technical support to meet the requirements to comply with the EMC specifications.

- United States Federal Communications Commission (FCC) Rules and Regulations (Class B), Part 15. IBM Corporate Standard C-S 2-0001-026 (A 6 dB buffer should be maintained on the emission requirements).
- European Economic Community (EEC) directive number 76/889 related to the control of radio frequency interference and the Verband Deutscher Elektrotechniker (VDE) requirements of Germany (GOP). IBM National Bulletin NB 2-0001-400, NB 2-0001-401, and NB 2-0001-403.
- Electrostatic Discharge Susceptibility limits for a Class 2 ESD environment specified in IBM Corporate Standard C-S 2-0001-005.
- Radiated Electromagnetic Susceptibility (RES) as specified in IBM Corporate Standard C-S 2-0001-012.

---

## 7.15 Safety

The following shows the safety standards for the different countries.

### 7.15.1 Underwriters Lab (UL) Approval

All models, IBM-H2172-S2, IBM-H2258-S3, and IBM-H2344-S4 comply with UL 1950.

### 7.15.2 Canadian Standards Authority (CSA) Approval

All models, IBM-H2172-S2, IBM-H2258-S3, and IBM-H2344-S4 comply with CSA C22.2 #950-M89.

### 7.15.3 IEC Compliance

All models, IBM-H2172-S2, IBM-H2258-S3, and IBM-H2344-S4 comply with IEC 380, IEC 435 and IEC 950.

## **7.15.4 German Safety Mark**

All models, IBM-H2172-S2, IBM-H2258-S3, and IBM-H2344-S4 were approved by TUV on Test Requirements: EN 60 950:1988/A2:1991.

## **7.15.5 Flammability**

Printed circuit boards used in this product are made of material with UL recognized flammability rating of V-1 or better. The flammability rating is marked or etched on the board. All other parts not considered electrical components are made of material with UL recognized flammability rating of V-1 or better, except minor mechanical parts.

## **7.15.6 Safe Handling**

The products are conditioned for safe handling in regards to sharp edges and corners.

## **7.15.7 Environment**

The product does not contain any known or suspected carcinogens.

Environmental controls meet or exceed all applicable government regulations in the country of origin. Safe chemical usage and manufacturing control are used to protect the environment. An environmental impact assessment has been done on the manufacturing process used to build the drive, the drive itself, and the disposal of the drive at the end of its life.

Production also meets the requirements of the international treaty on chlorofluorocarbon (CFC) control known as the United Nations Environment Program Montreal Protocol, and as ratified by the member nations. Materials to be controlled include CFC-11, CFC-12, CFC-113, CFC-114, CFC-115, Halon 1211, Halon 1301 and Halon 2402. Although not specified by the Protocol, CFC-112 is also controlled. In addition to the above protocol, IBM controls the following:

- All packaging materials used for the shipment of the product do not use controlled CFCs in the manufacturing process.
- All manufacturing processes for parts or assemblies including printed circuit boards, will not use the controlled CFC materials after December 31, 1993.

### **7.15.8 Secondary Circuit Protection**

The drive uses printed circuit wiring that protects the possibility of sustained combustion due to circuit or component failure. Adequate secondary over-current protection is the responsibility of the using system.

The host system must protect the drive from any electrical short circuit problem. A 10 amperes limit is required for safety purposes.

---

## **7.16 Packaging**

The drives are packed in ESD protective bags for shipping.

# 8.0 Electrical Interface Specifications

## 8.1 Driver/Receiver

The drives support single ended drivers and receivers.

## 8.2 Connector

The SCSI signal connectors are designed to mate with AMP part number 176135 or equivalent. Figure 3 shows the pin locations on the connectors.

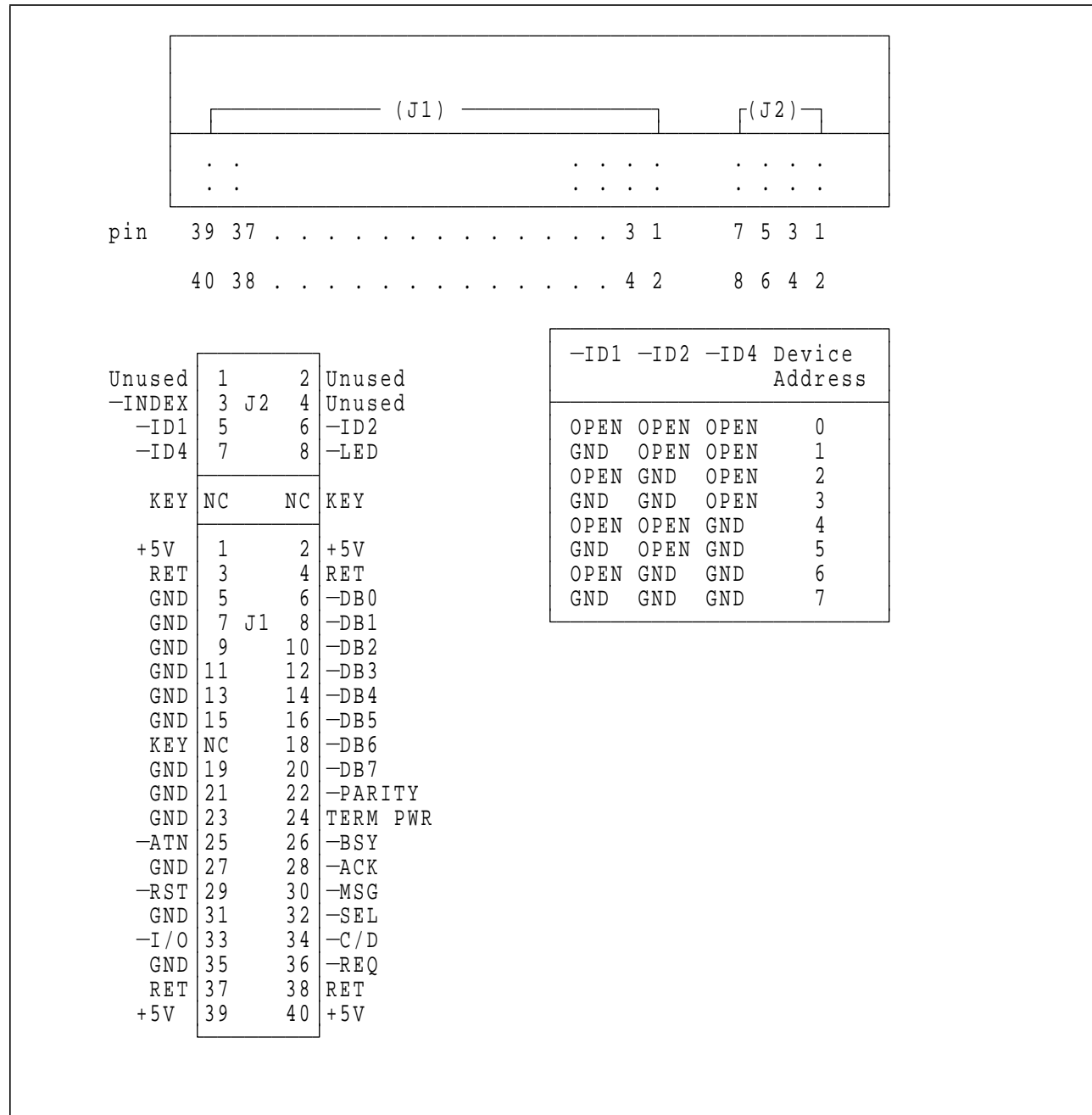

Figure 3. 40-pin SCSI Connector

## 8.3 Signal Definition

The pin assignments of interface signals are listed as follows:

PIN	SIGNAL NAME	PIN	SIGNAL NAME
01	+5V	02	+5V
03	RET	04	RET
05	GND	06	DB0
07	GND	08	DB1
09	GND	10	DB2
11	GND	12	DB3
13	GND	14	DB4
15	GND	16	DB5
17	KEY	18	DB6
19	GND	20	DB7
21	GND	22	PARITY
23	GND	24	TERMPWR
25	-ATTN	26	-BSY
27	GND	28	-ACK
29	-RST	30	-MSG
31	GND	32	-SEL
33	-I/O	34	-C/D
35	GND	36	-REQ
37	RET	38	RET
39	+5V	40	+5V

Figure 4. J1 Signal Assignment

PIN	SIGNAL NAME	PIN	SIGNAL NAME
1	(Unused)	2	(Unused)
3	-INDEX	4	(Unused)
5	-ID1	6	-ID2
7	-ID4	8	-LED

Figure 5. J2 Signal Assignment

### 8.3.1 Signal Line Descriptions

Name	Description
<b>BSY</b>	BUSY indicates that the bus is in use.
<b>SEL</b>	SELECT is used by an Initiator to select a Target or by a Target to re-select an Initiator.
<b>C/D</b>	CONTROL DATA indicates whether control (1) or data (0) information is on the bus.
<b>I/O</b>	INPUT/OUTPUT indicates whether the data on the bus is an input (1) to the Initiator or an output (0) to the Target. This line is also used to differentiate between SELECTION phase (0) and RE-SELECTION phase (1).

<b>MSG</b>	MESSAGE is driven by Target and indicates a message phase.
<b>REQ</b>	REQUEST is driven by Target and indicates a request for a REQ/ACK data transfer handshake.
<b>ACK</b>	ACKNOWLEDGE is driven by the Initiator and indicates an acknowledgement of a REQ/ACK data transfer handshake.
<b>ATN</b>	ATTENTION is driven by an Initiator to inform a Target that the Initiator has a message ready.
<b>RST</b>	RESET clears all SCSI devices from the bus and resets them.
	<b>Note:</b> The target will not drive this line.
<b>DB(n)</b>	8 data bits are used to transfer data over the bus. DB (7) is the most significant.
<b>DB(P)</b>	PARITY bit associated with DB (7-0). Data parity is odd.
<b>ID(n)</b>	These signal pins are used to set the drive address.
<b>INDEX</b>	The signal is for reference, and the function is not specified.
<b>LED</b>	The signal is for reference, and the function is not specified.

---

## 8.4 Cabling

The maximum cable length from the host system to the drive is limited to 6 meters with external standard termination (220  $\Omega$  to the TERMPWR line and 330  $\Omega$  to ground) or equivalent.

The maximum cable length depends on the condition of various electrical parameters of the interface. IBM will offer technical guidance on a request basis.

---

## 8.5 Device Address

The drive recognizes its device address, namely SCSI ID, with the condition of -ID1, -ID2 and -ID4. The signal condition and the device address are shown in Figure 3 on page 27.

---

## 8.6 Signal Termination

The drive does not have termination nor pull up resistors for the SCSI interface.









SC18-2284-00