

64K × 4 Bit Static RAM

FEATURES

- Fast Access Time 25, 35, 45ns (max.)
- Low Power Dissipation
Standby (TTL) : 2mA (max.)
(CMOS): 100µA (max.)
Operating : 100mA (max.)
- Single 5V ± 10% supply
- TTL compatible inputs and outputs
- Full Static Operation
—No clock or refresh required
- Common I/O, Tristate Output
- Low Data Retention Current: 50µA (max.)
- Battery Back-up Operation
—2V (min.) Data Retention
- Standard 24-pin DIP (300 mil)

GENERAL DESCRIPTION

The KM64257 is a 262,144-bit high speed Static Random Access Memory organized as 65,538 words by 4 bits. The device is fabricated using Samsung's advanced CMOS process.

The KM64257 has a chip enable input for the minimum current power down mode.

The KM64257 has been designed for high speed applications. It is particularly well suited for the use in high speed and low power applications in which battery back up for nonvolatility is required.

FUNCTIONAL BLOCK DIAGRAM

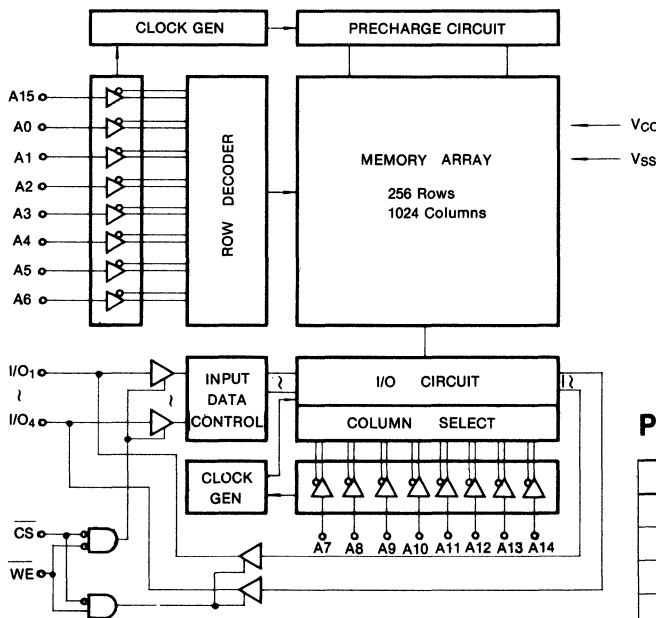

PIN CONFIGURATION

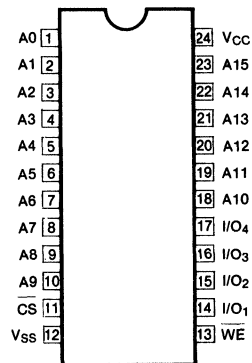

PIN NAMES

Pin Name	Pin Function
A ₀ -A ₁₅	Address Inputs
WE	Write Enable
CS	Chip Select
I/O ₁ -I/O ₄	Data Inputs/Outputs
V _{CC}	+5V Power Supply
V _{SS}	Ground